

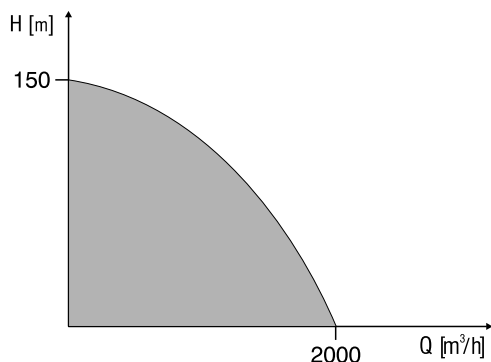

## OBSZAR UŻYTKOWANIA

Wydajność	do 2000 m <sup>3</sup> /h
Wys. podnoszenia	do 150 m
Maksymalne ciśnienie robocze	1,6 MPa
Zakres temperatury	-10 ÷ 140°C
Temperatura otoczenia	max. 40°C
Średnica króćców	32 ÷ 300 mm



## PRZEZNACZENIE

Pompy NPK przeznaczone są do tłoczenia cieczy rzadkich, czystych i nieagresywnych bez cząstek stałych i włóknistych o temperaturze nie przekraczającej 140°C.

Pompowane ciecze nie mogą posiadać właściwości wybuchowych oraz reagować mechanicznie i chemicznie z materiałami, z których wykonano elementy pompy.

## ZASTOSOWANIE

- instalacje ciepłne,
- instalacje zasilania w wodę,
- instalacje klimatyzacyjne,
- instalacje chłodnicze,
- instalacje przeciwpożarowe, hydrantowe,
- instalacje przemysłowe,
- instalacje nawadniające,
- instalacje wodociągowe.

## KONCEPCJA BUDOWY

### część hydrauliczna

- pompa i silnik zamontowany na wspólnej podstawie,
- korpus z żeliwa szarego,
- ssanie w osi poziomej, tłoczenie w osi pionowej do góry,
- wirnik z żeliwa szarego,
- uszczelnienie mechaniczne typu BAQE (inne na życzenie),
- sprzęgło elastyczne demontowalne.

### silnik

- trójfazowy z krótkim wałem, asynchroniczny na łapach,
- połączony z wałem pompy przy pomocy elastycznego sprzęgła w osłonie,
- kierunek obrotów w prawo (patrząc od strony napędu),
- napięcie 3 x 230/400, 400V,
- częstotliwość 50 Hz.
- wymagane pełne zewnętrzne zabezpieczenie elektryczne,
- klasa izolacji F,
- stopień ochrony IP55.

## ZALETY

- duża niezawodność,
- łatwość montażu i demontażu,
- znormalizowane wymiary,
- rozbudowany typoszereg,
- silniki standardowe,
- szeroki zakres zastosowania,
- wysoka sprawność,
- szybki serwis gwarancyjny i pogwarancyjny.

## BUDOWA

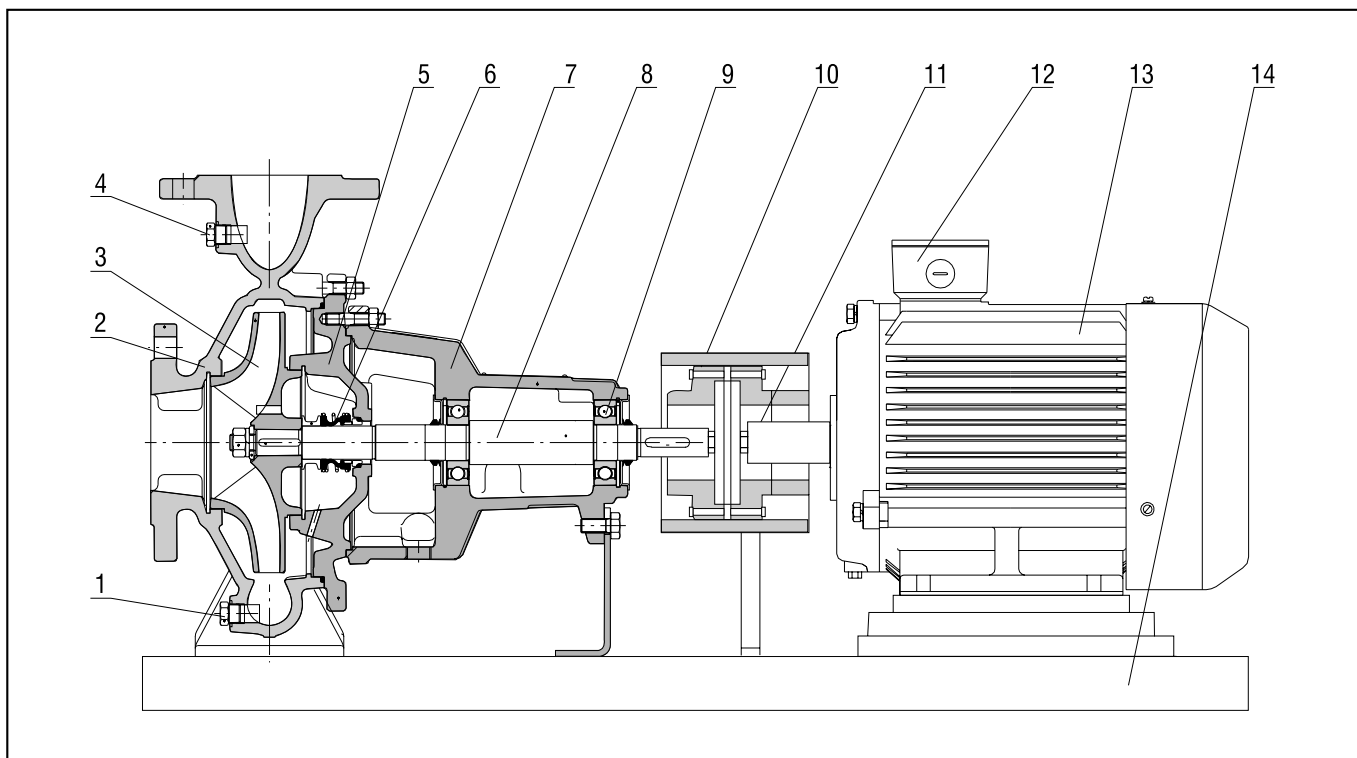

Lp.	Nazwa części	Materiał	Lp.	Nazwa części	Materiał
1.	Korek spustowy	MO 59	8.	Wał pompy	St 5
2.	Korpus pompy	EN-GJL-250 (ZI250)	9.	Łożysko	
3.	Wirnik	EN-GJL-250 (ZI250)	10.	Ośłona sprzęgła	
4.	Korek zalewowy	MO 59	11.	Sprzęgło demontowalne	
5.	Pokrywa	EN-GJL-250 (ZI250)	12.	Szkrzynka zaciskowa	
6.	Dławnica	EN-GJL-250 (ZI250)	13.	Silnik	
7.	Korpus łożyskowy	EN-GJL-250 (ZI250)	14.	Podstawa pompy	EN-GJL-250 (ZI250)

### Dławnica mechaniczna BAQE

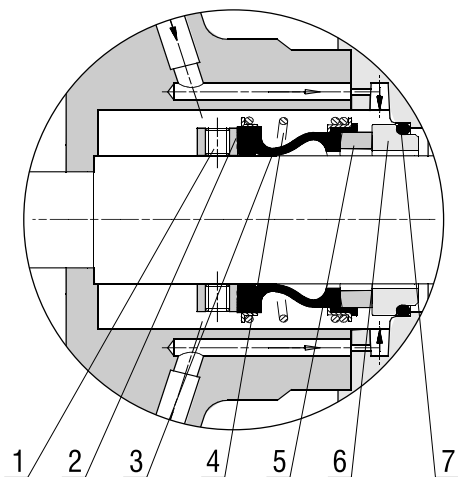

Dławnica	Typ uszczelnienia (3)	Pierścień obrotowy (5)	Pierścień stały (6)	Elastometr (7)
BAQE	B	A	Q	E
BQQE*	B	Q	Q	E
BAQV*	B	A	Q	V

B - uszczelnienie mieszkami gumowym

A - grafit impregnowany

Q - węgiel krzemowy

E - EPDM

V - FKM

\* dławnice na specjalne życzenie

- 1. Pierścień oporowy
  - 2. Koszyk sprężyny
  - 3. Mieszek gumowy
  - 4. Sprężyna
  - 5. Pierścień obrotowy
  - 6. Pierścień stały
  - 7. Uszczelka pierścienia stałego
- } elementy 2÷5 stanowią jeden niedemontowalny element

## KLUCZ OZNACZEŃ

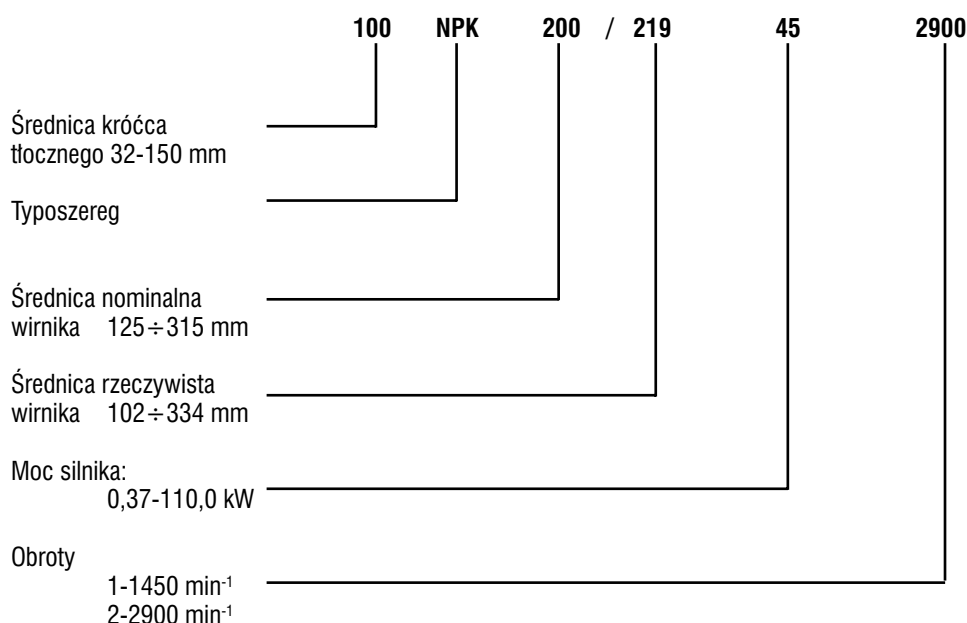

## ZAKRES STOSOWALNOŚCI

### Zakres stosowalności

Normowe pompy klasyczne typu NPK przeznaczone są do pompowania rozmaitych cieczy. Ciecze powinny być rzadkie, nie wybuchowe, pozbawione cząstek stałych i długowłókniстых. Ciecze nie mogą reagować chemicznie z materiałami pompy.

Typowe zastosowania	
<b>Zasilanie w wodę</b>	
- w sieciach wodociągowych	•
- dystrybucja z sieci wodociągowej	•
- podwyższanie ciśnienia w sieci zasilającej	•
- podwyższanie ciśnienia w budynkach, hotelach itp.	•
- podwyższanie ciśnienia w przemysłowych instalacjach wodociągowych	•
- instalacje basenowe	•
- instalacje grzewcze	•
- sieci ciepłownicze	•
<b>Podnoszenie ciśnienia w:</b>	
- technologicznych systemach wodnych	•
- systemach mycia i czyszczenia	•
- myjniach pojazdów	•
- instalacje przeciwpożarowe hydrantowe	•
<b>Przepompowywanie cieczy w:</b>	
- systemach chłodzenia i klimatyzacji (czynniki chłodnicze)	•
- systemach zasilania kotłów	•
- gospodarstwach rolnych i produkcyjnych	•
<b>Nawadnianie</b>	
- nawadnianie pól	•
- deszczownie	•
- nawadnianie kropłowe (instalacje zraszające)	•

Pompy przeznaczone są do pompowania rozmaitych cieczy w szerokiej gamie stężeń, temperatur oraz ciśnień. Poniższa tabela zawiera wykaz typowych cieczy, które mogą być pompowane przy użyciu odpowiedniego uszczelnienia.

Tłoczona ciecz	Uwagi	Informacje dodatkowe	Uszczelnienie wału
Woda gruntowa		> +90°C	BAQE
Woda kotłowa		> +120°C	BAQE
Woda grzewcza		> +120°C	BAQE
Kondensat		+90°C - +120°C	BAQE
Woda zmiękczona	C	> +90°C	BAQE
Alkohol etylowy	B, D, F, I	+70°C	BAQE
Alkohol metylowy	B, D, F, I	+40°C	BAQE
Olej silikonowy	B, H		BAQE
Rozpuszczalniki organiczne	F, G	< +60°C	BAQE
Woda amoniakalna		Max. 10%, 40°C	BAQE
Płyn hamulcowy		Max. 40°C	BAQE
Mieszanka glikol-woda		-10°C do 80°C	BAQE
Woda i ciecze chłodzące		0°C do 120°C	BAQE
Woda czysta i pitna			BAQE
Woda słonawa	J, L	ph>6.5, +40°C, 1000ppm Cl	BQQE
Glikol	B, D	+50°C, 50%	BQQE
Solanka	B, D, C	+5°C, 30%	BQQE
Olej napędowy	F, G, H, I	< +20°C, 100%	BAQV
Nafta	F, G, H, I	< +20°C, 100%	BAQV
Benzyna	F, G, H, I	< +20°C, 100%	BAQV
Ropa naftowa	F, G, H, I	< +20°C, 100%	BAQV
Oleje roślinne	D, B, I, H		BAQV
Środki czyszczące	A, H	< +80°C, 100%	BQQE
Sole (wodorotlenki, azotany, siarczany)	A	< +20°C, <15%	BQQE
Wodorotlenek amonu, wapnia, sodu		< +100°C, <30%	BQQE

Dla cieczy o lepkości i ciężarze właściwym większym niż wody wymagane jest uzgodnienie mocy silnika.

W katalogu przedstawiono charakterystyki wykonań standardowych.

Możliwe jest wykonanie pomp o innych parametrach (średnica wirnika, moc silnika itp.) niż przedstawiono w katalogu.

## TEMPERATURA OTOCZENIA

Maksymalna temperatura otoczenia pracy pompy wynosi +40 °C

Jeżeli temperatura otoczenia jest wyższa niż 40 °C lub pompa pracuje na wysokości powyżej 1000 m.n.p.m. należy zmniejszyć moc P2 z powodu mniejszej gęstości powietrza. W takich przypadkach konieczne może być zastosowanie silnika o większej mocy.

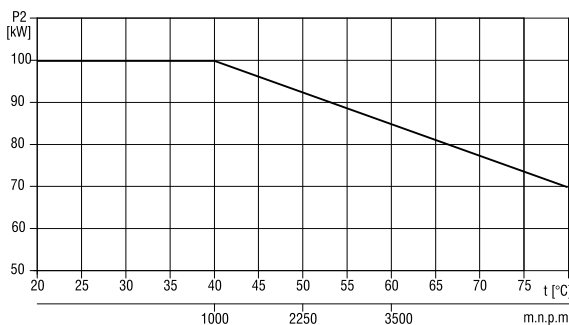

## DOBÓR POMPY TYPU NPK

Podczas doboru pomp normowych NPK należy uwzględnić:

- wymagane ciśnienie i wydajność w punkcie pracy,
- straty ciśnienia wynikające z różnicy wysokości,
- straty ciśnienia w rurociągach. W przypadku długich rurociągów, dużej ilości kolan lub zaworów itp. może być konieczne obliczenie strat ciśnienia.
- najlepszą sprawność w punkcie pracy.

Dobierając pompę, która pracuje zawsze w tym samym punkcie pracy, należy dobrać taką pompę, której punkt pracy odpowiada najlepszej sprawności.

Przy doborze odpowiedniego wykonania materiałowego pompy należy zwrócić uwagę na tłoczoną ciecz i jej właściwości.

## WARUNKI WAŻNOŚCI CHARAKTERYSTYK

Dla zamieszczonych w katalogu charakterystyk obowiązują następujące warunki:

- krzywe odnoszą się do wody o temperaturze 20 °C,
- krzywe odnoszą się do prędkości obrotowej silników przy 50 Hz,
- konwersja pomiędzy wysokością podnoszenia [H], a ciśnieniem "p[kPa]" odnosi się do wody o gęstości  $\rho = 1000 \text{ kg/m}^3$ ,  
W przypadku gdy gęstość cieczy jest inna niż  $1000 \text{ kg/m}^3$  ciśnienie tłoczenia jest proporcjonalne do gęstości.  
W przypadku tłoczenia cieczy o gęstości większej niż  $1000 \text{ kg/m}^3$ , należy zamontować silniki o odpowiednio większej mocy.
- Wartości krzywych odnoszą się do lepkości kinematycznej  $\nu = 1 \text{ mm}^2/\text{s}$  (1cSt).  
Maksymalna lepkość kinematyczna, nie wymagająca przeliczenia mocy silnika, wynosi  $3 \text{ mm}^2/\text{s}$ .

Pompa nie powinna pracować z wydajnością minimalną poniżej  $0,1 \times Q$  przy optymalnej sprawności, ponieważ może to być przyczyną przegrzania pompy.

Ciecz: Woda pozbawiona powietrza.

Podczas doboru należy dodać margines bezpieczeństwa co najmniej 0,5 m.

Dla cieczy o lepkości i ciężarze właściwym większym niż wody wymagane jest uzgodnienie mocy silnika.

W katalogu przedstawiono charakterystyki wykonania standardowych.

Możliwe jest wykonanie pomp o innych parametrach (średnica wirnika, moc silnika itp.) niż przedstawiono w katalogu.

$n = 1450 \text{ min}^{-1}$

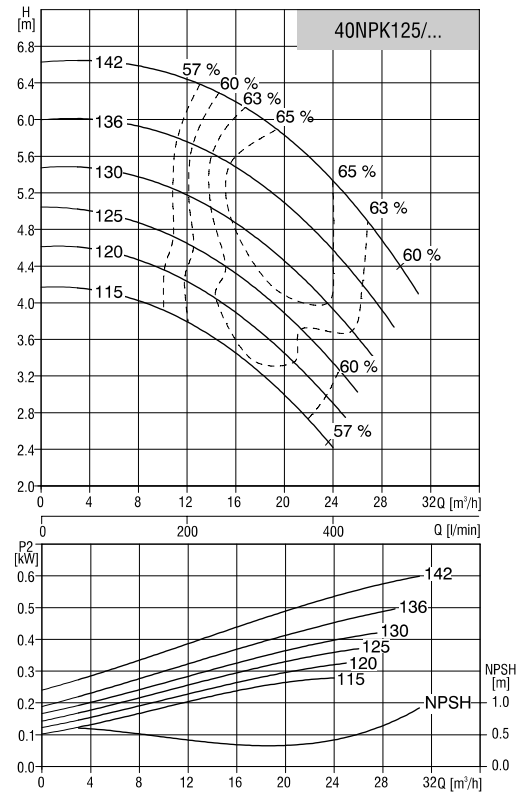
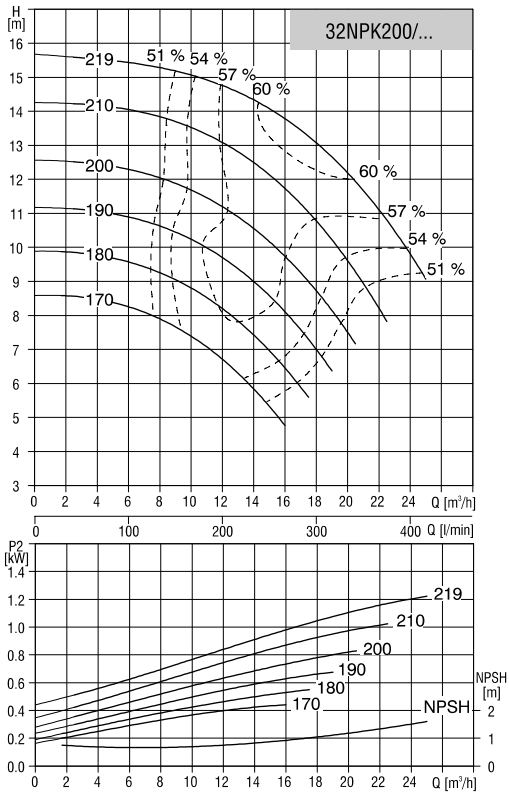
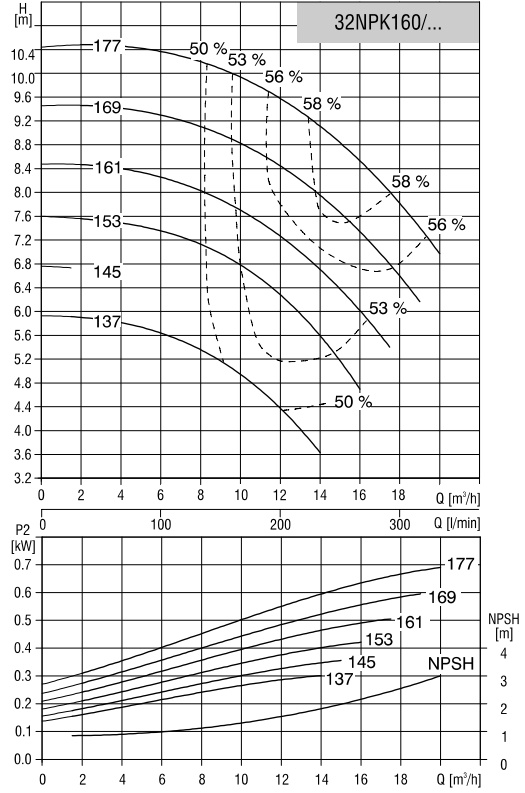
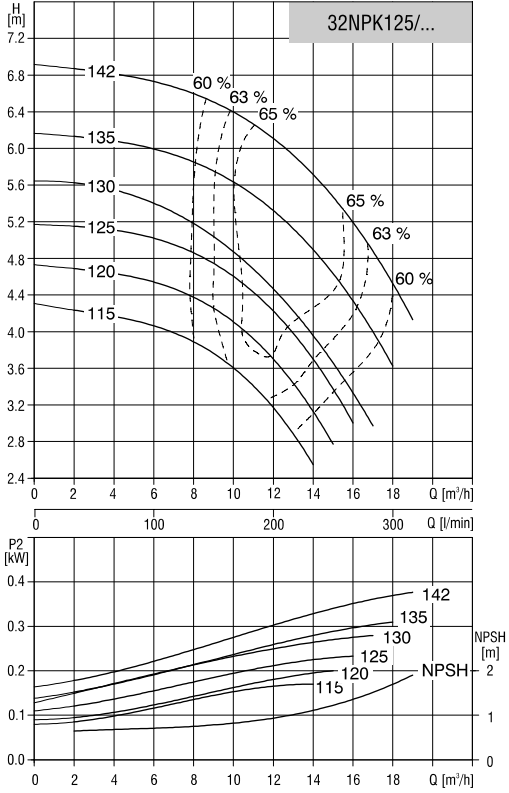

$n=1450 \text{ min}^{-1}$

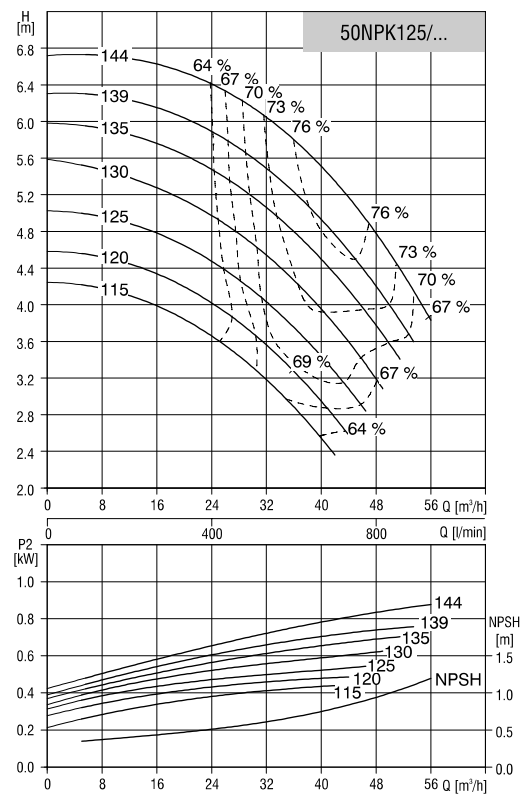
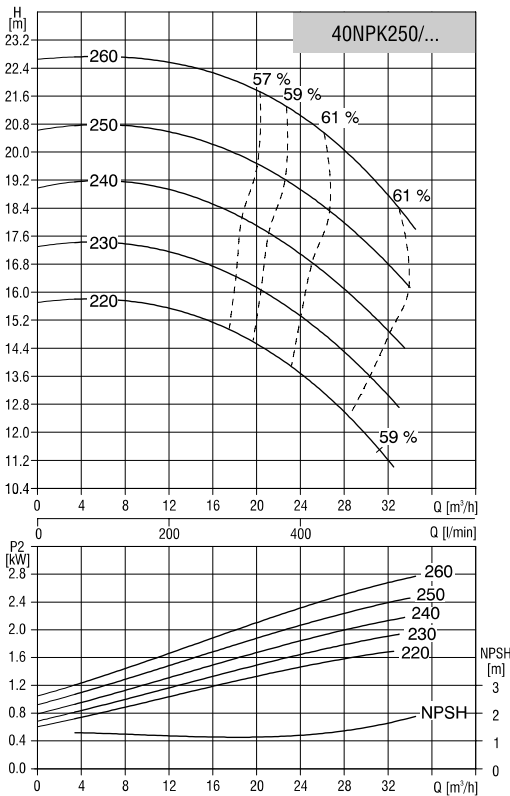
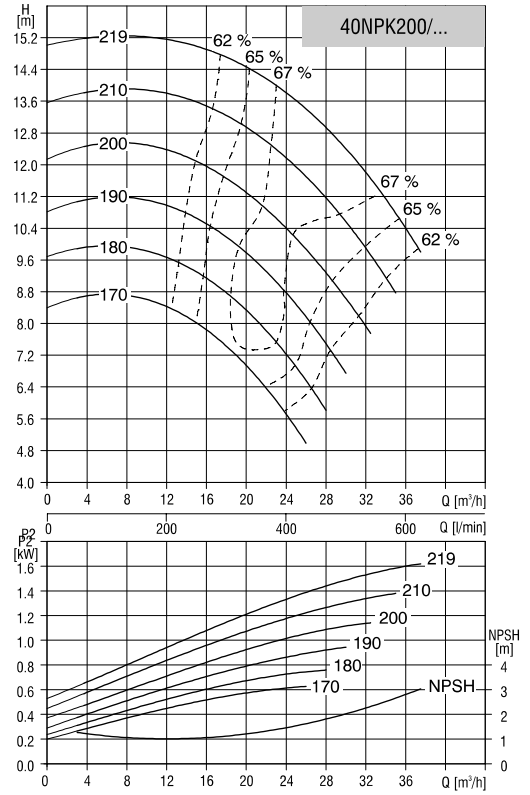
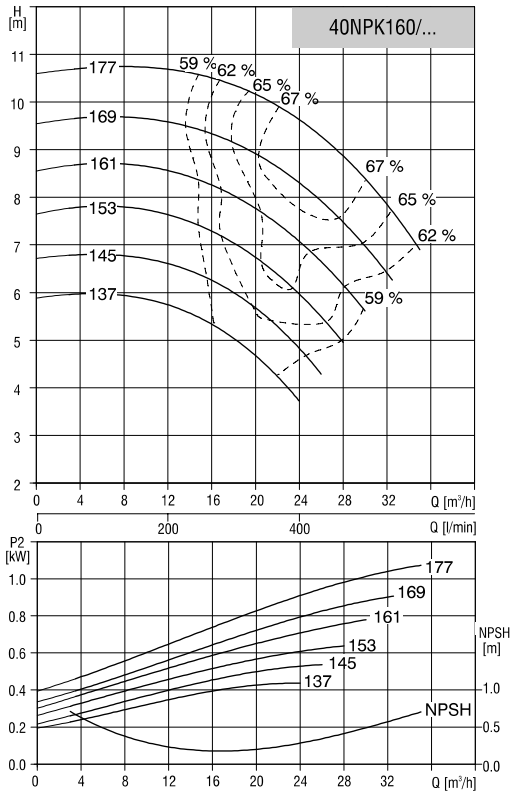

$n = 1450 \text{ min}^{-1}$

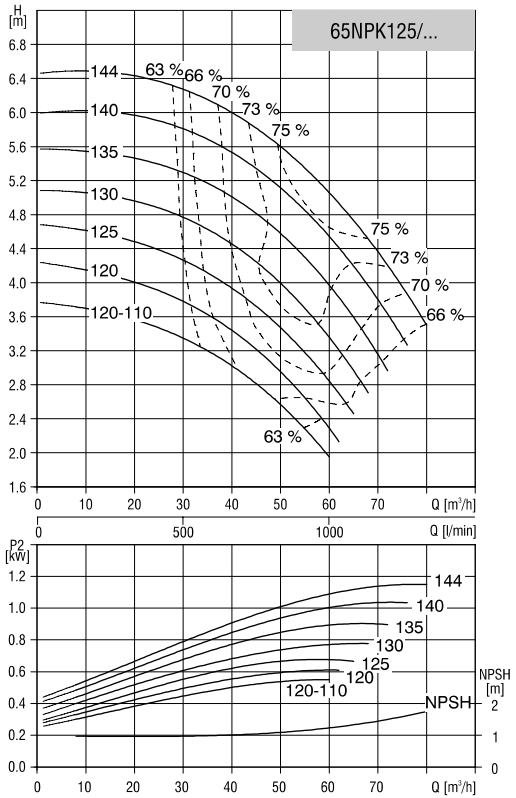
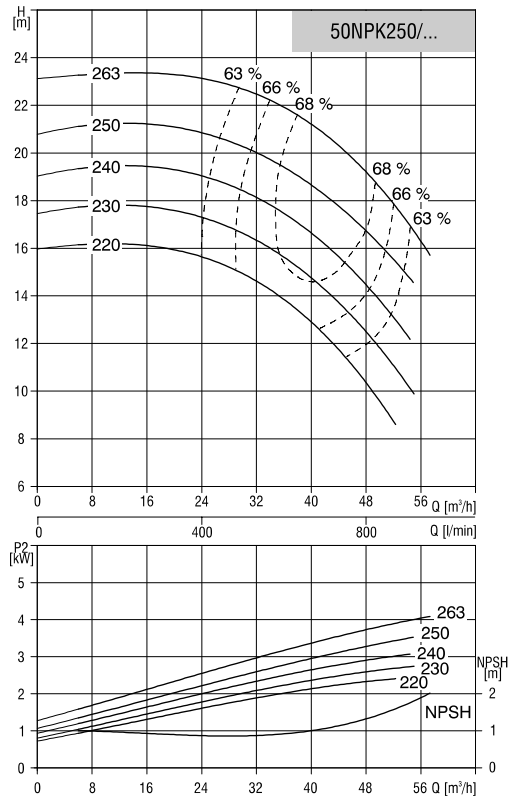
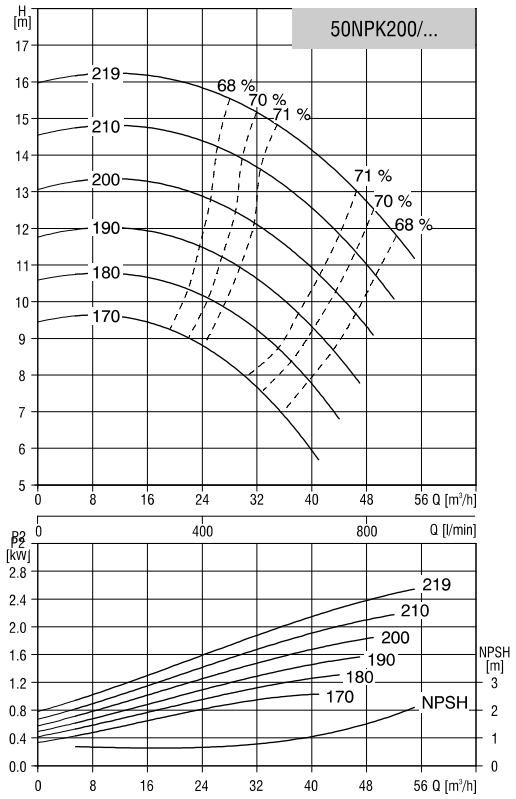
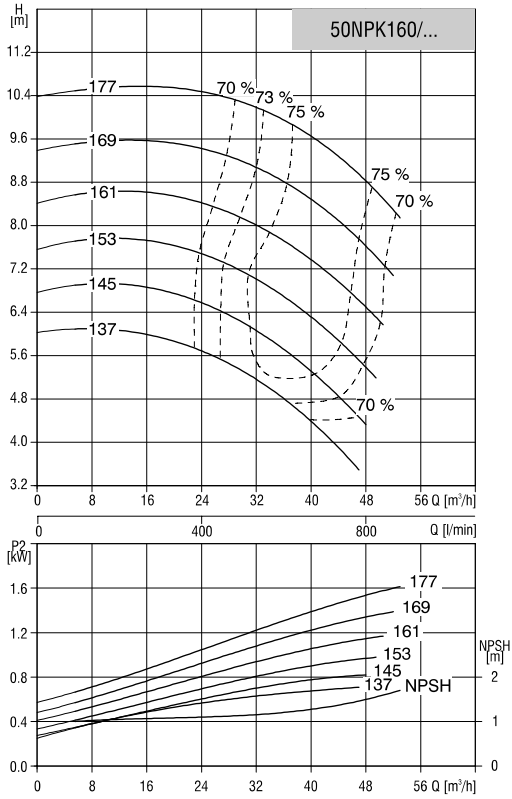

$n=1450 \text{ min}^{-1}$

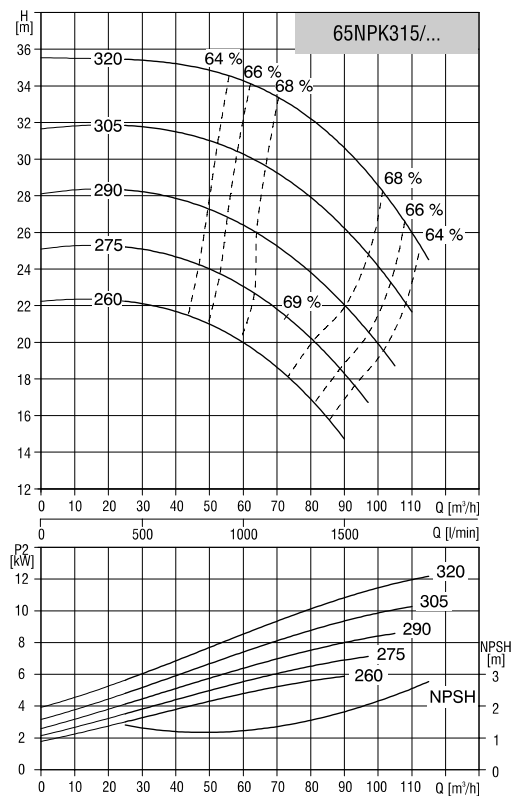
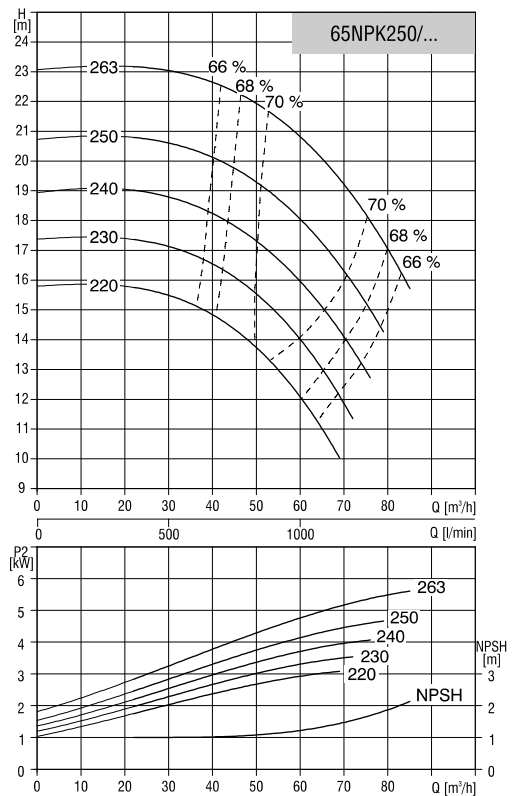
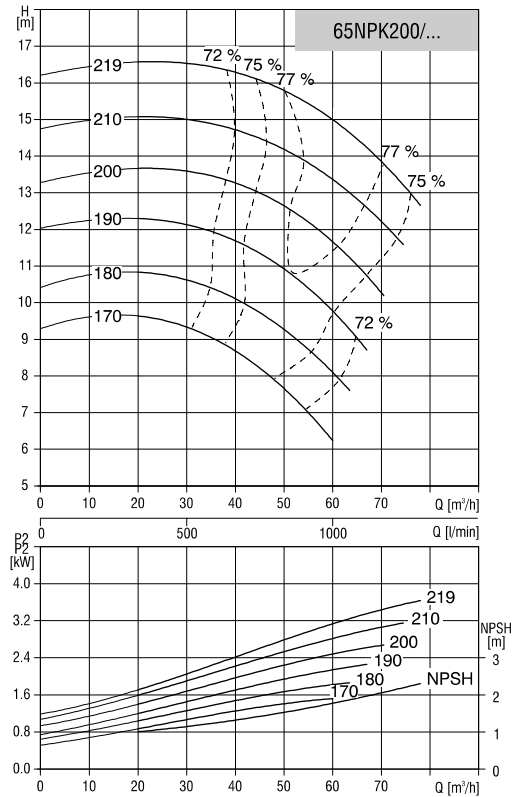
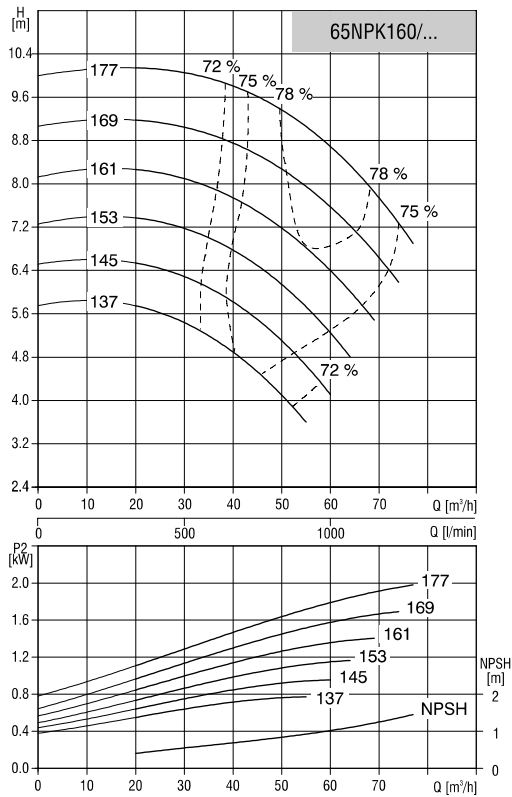

$n = 1450 \text{ min}^{-1}$

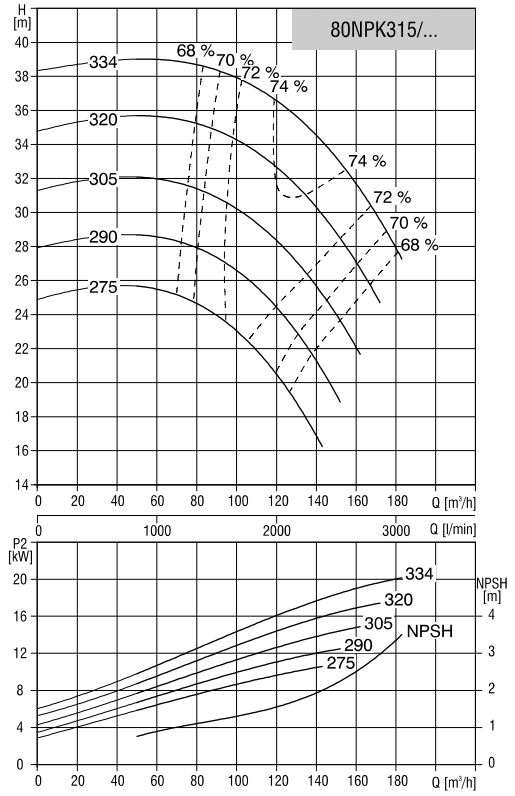
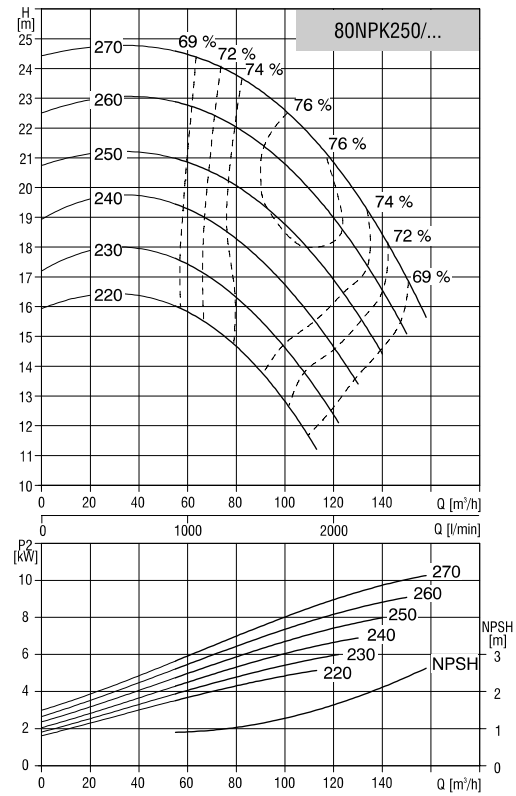
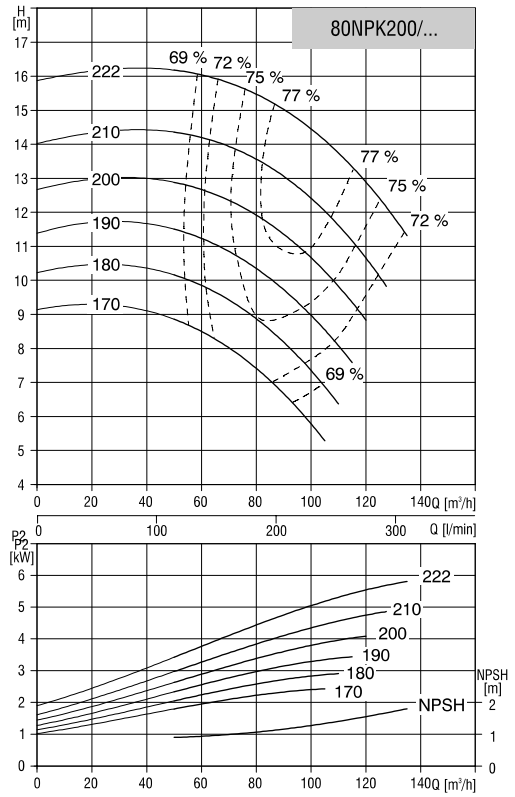
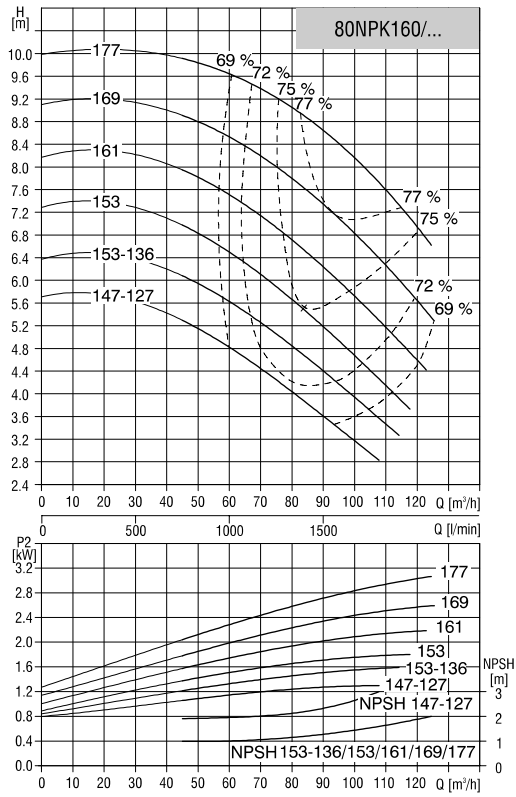

$n = 1450 \text{ min}^{-1}$

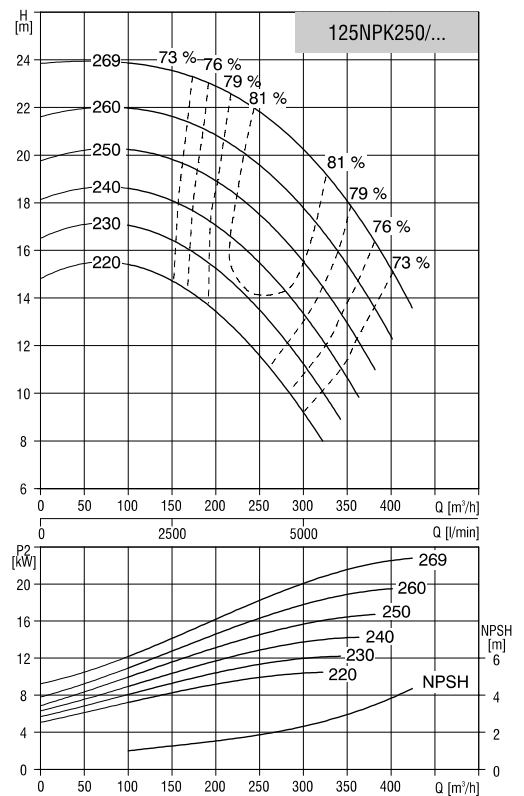
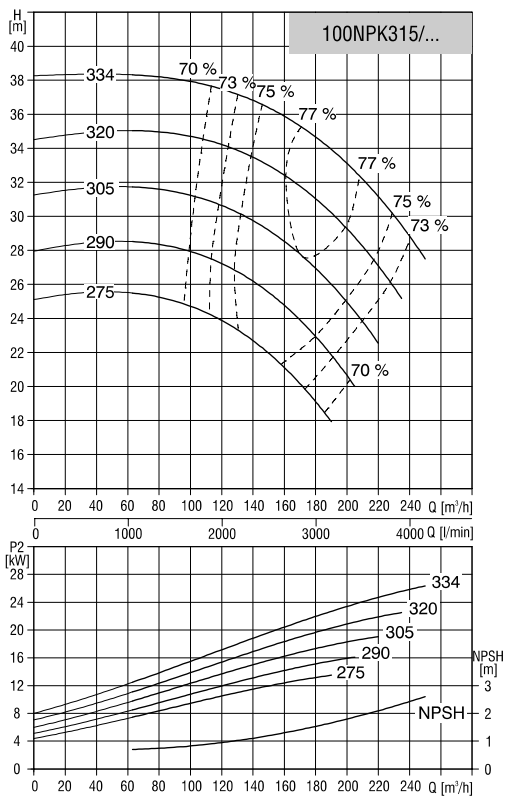
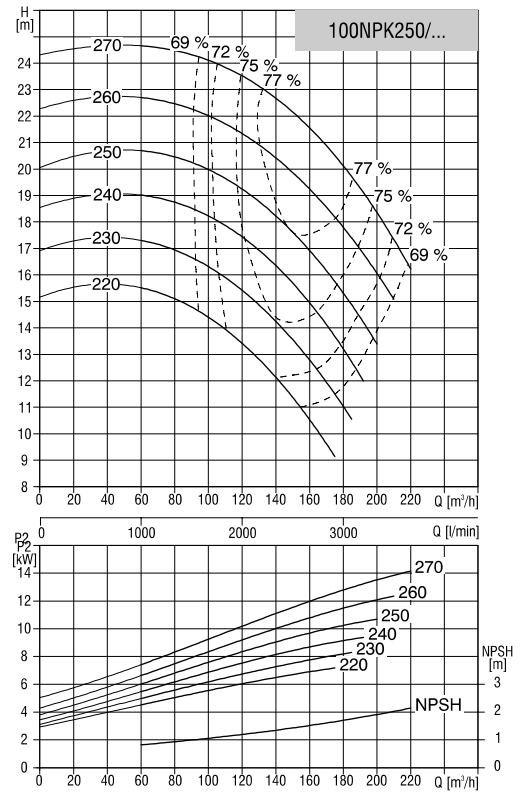
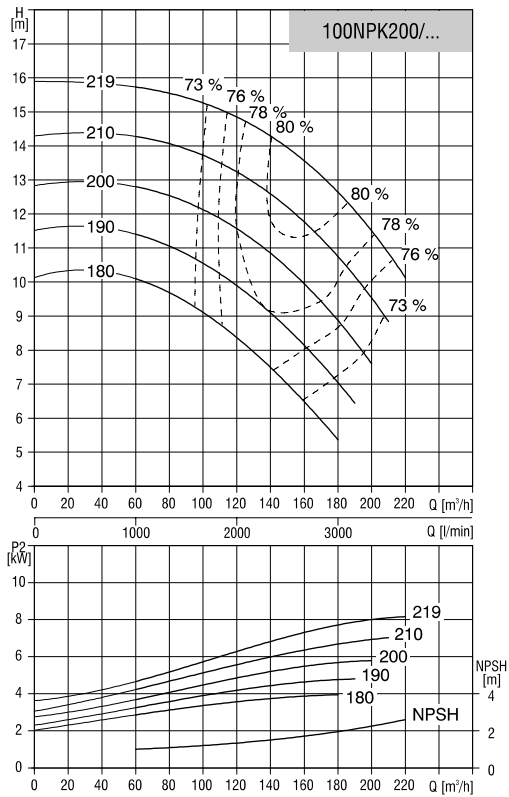

$n = 1450 \text{ min}^{-1}$

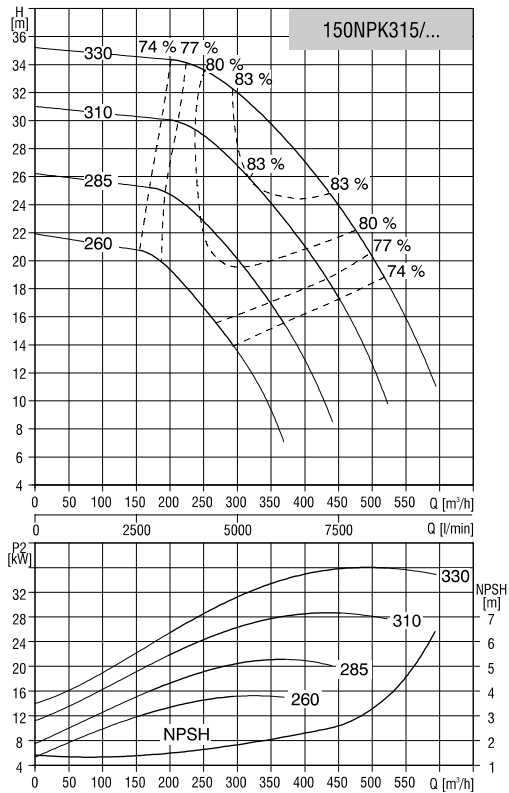
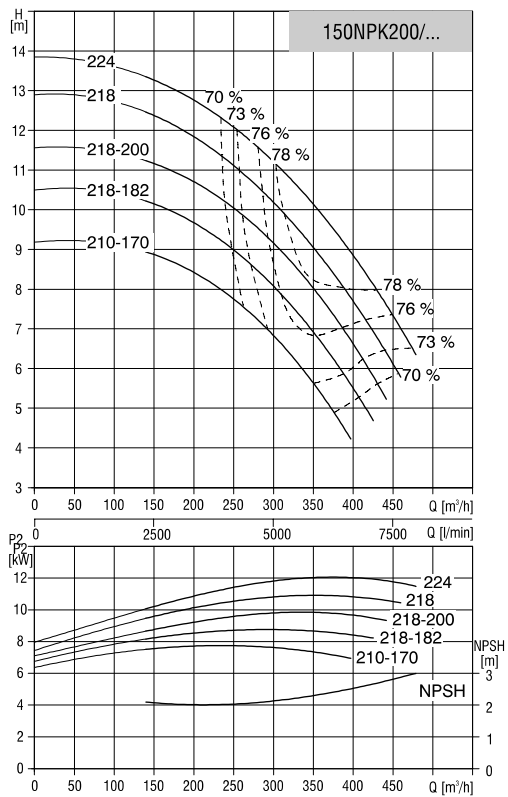
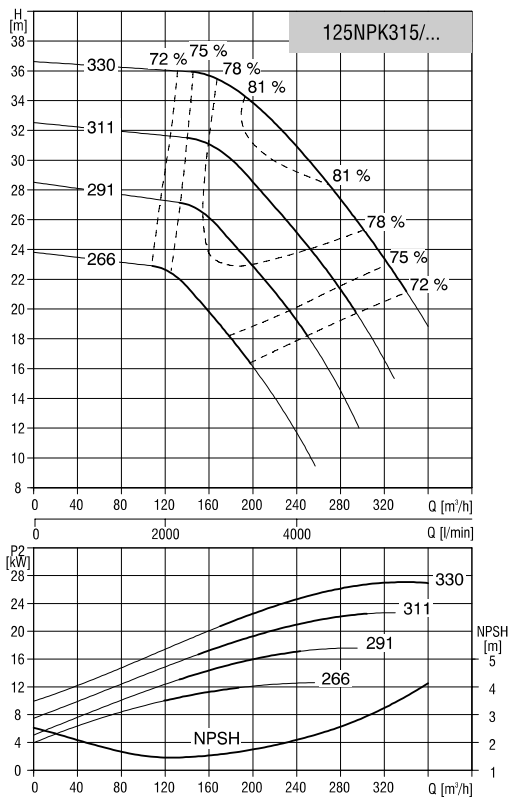

$n=2900 \text{ min}^{-1}$

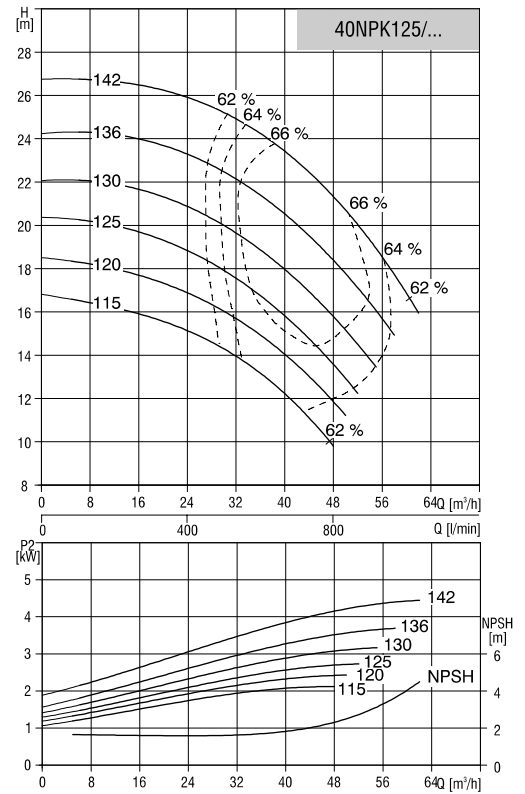
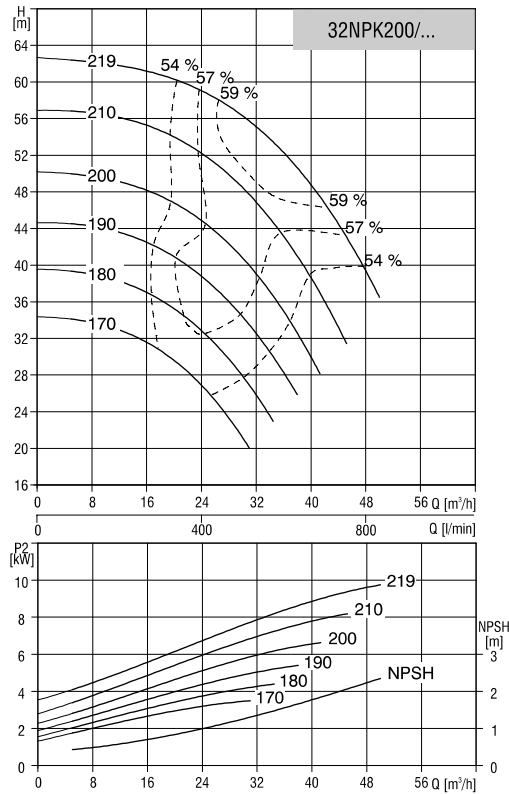
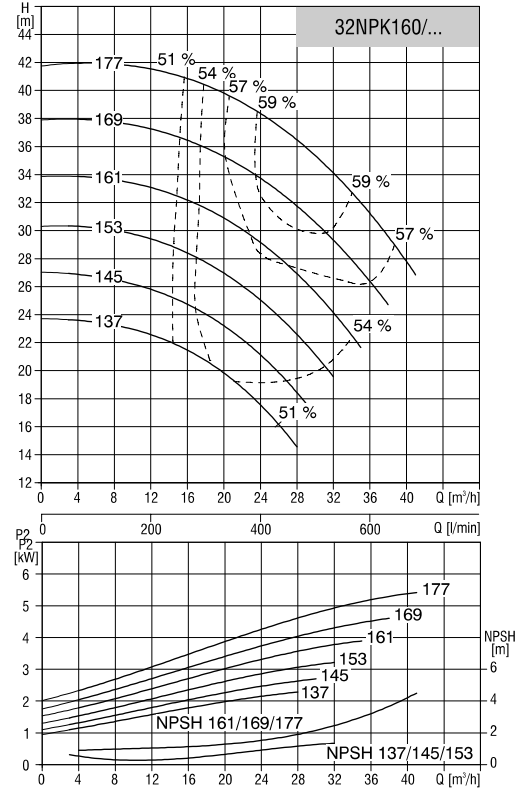
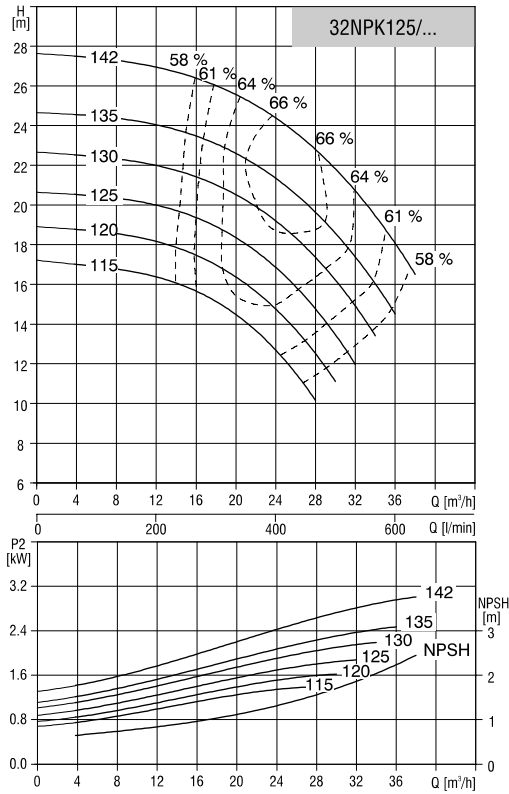

$n=2900 \text{ min}^{-1}$

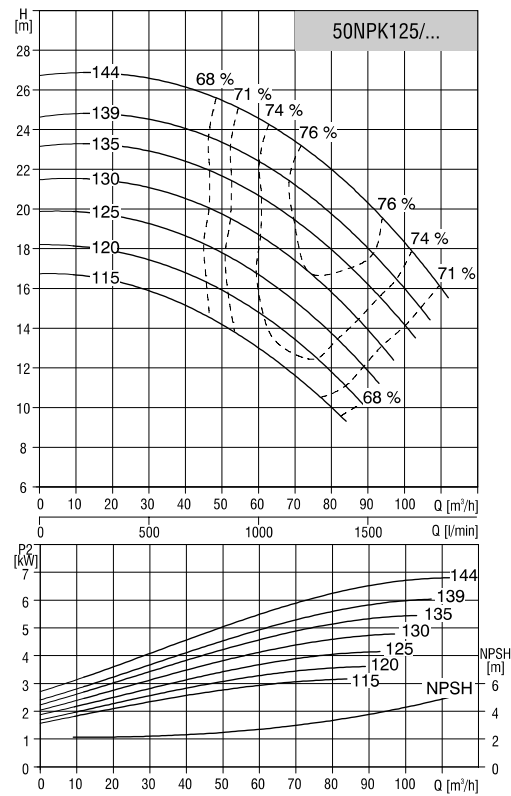
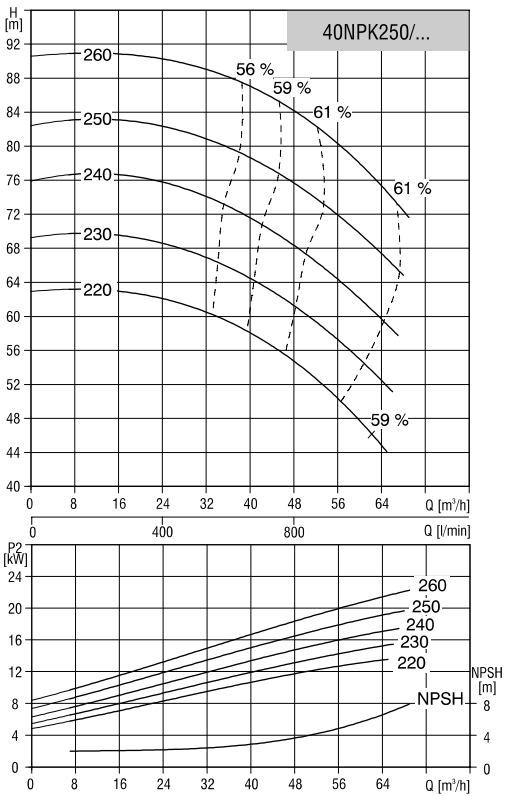
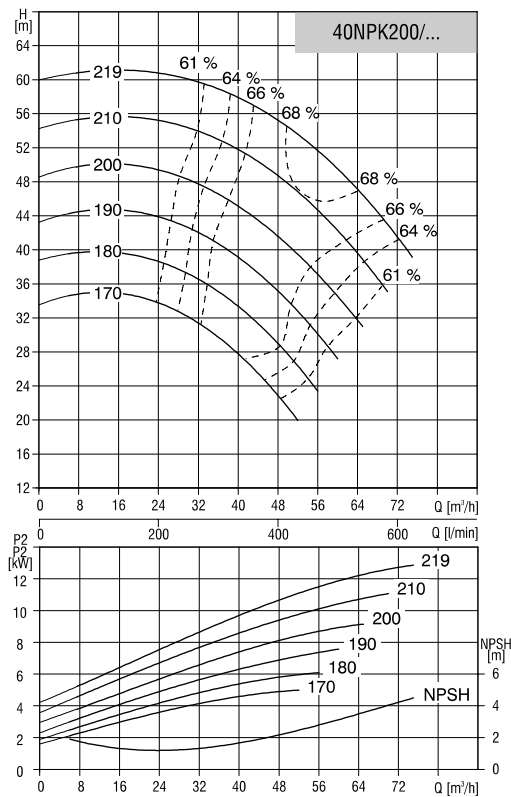
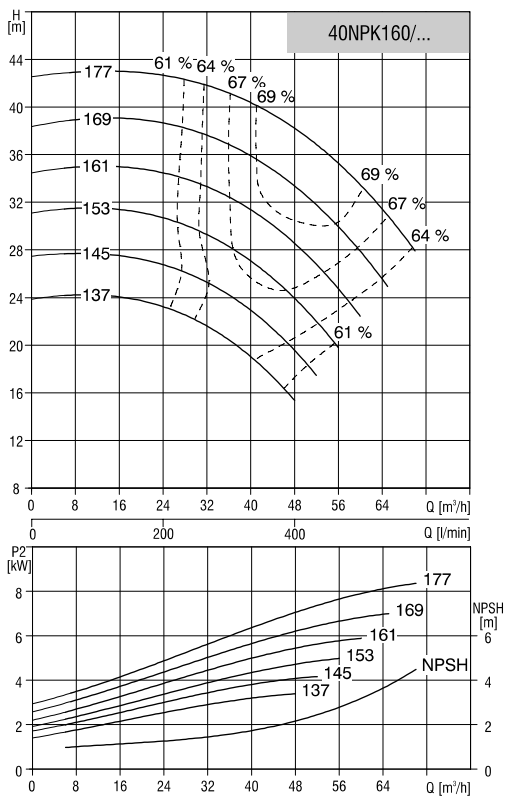

$n=2900 \text{ min}^{-1}$

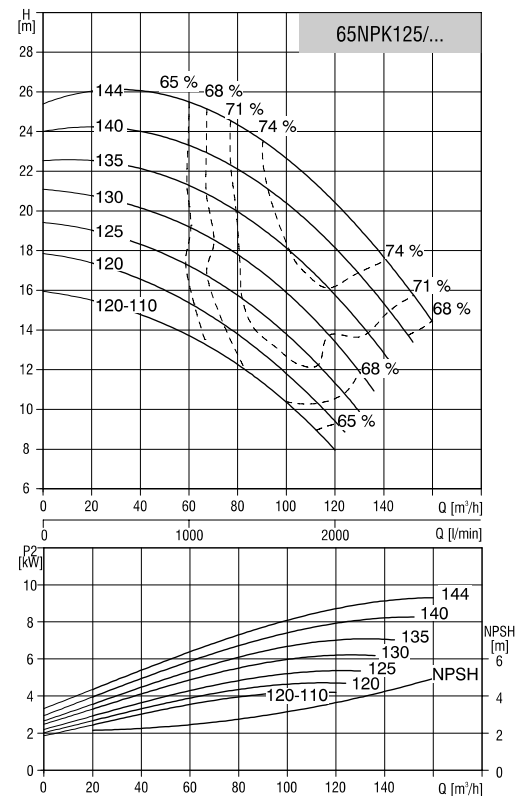
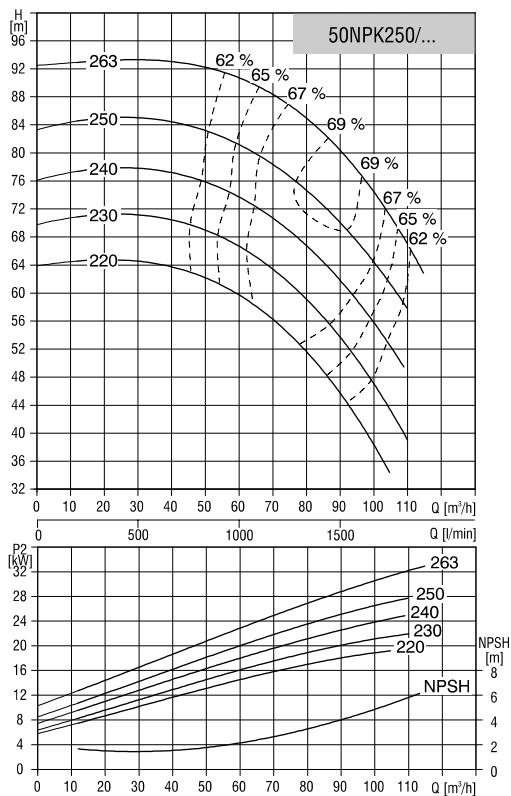
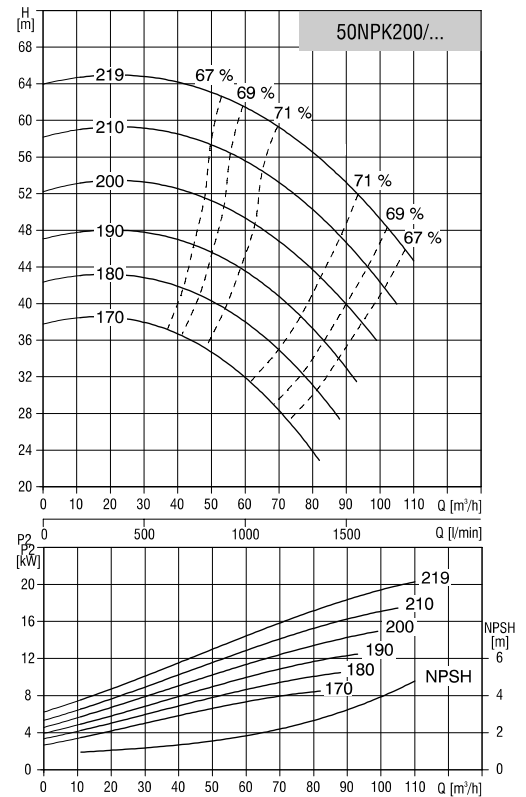
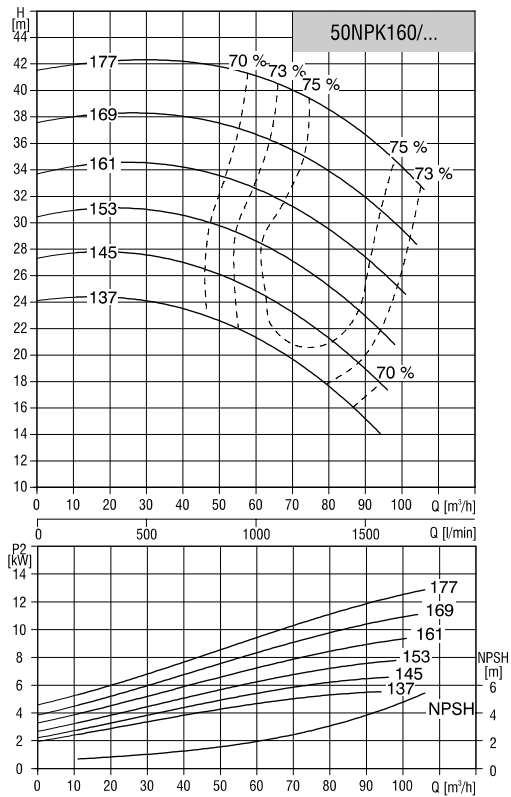

$n=2900 \text{ min}^{-1}$

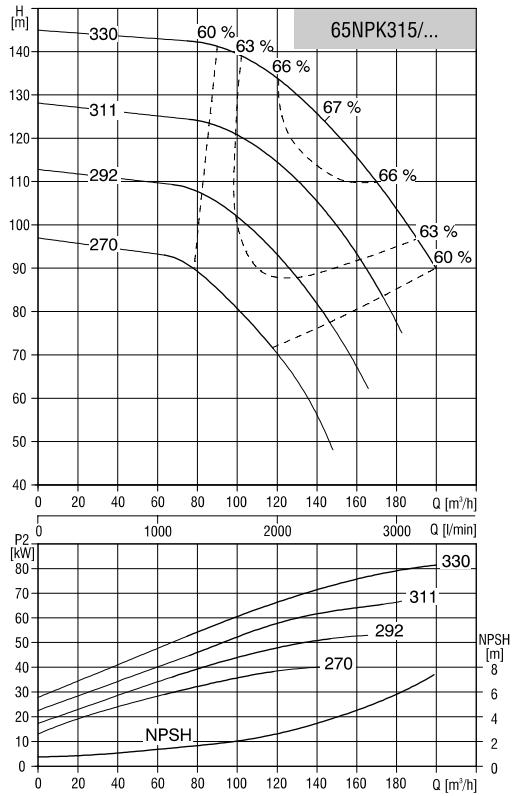
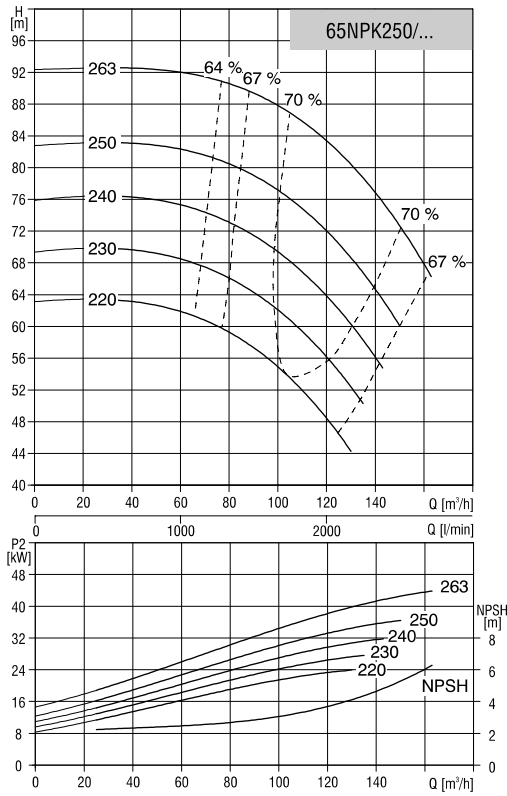
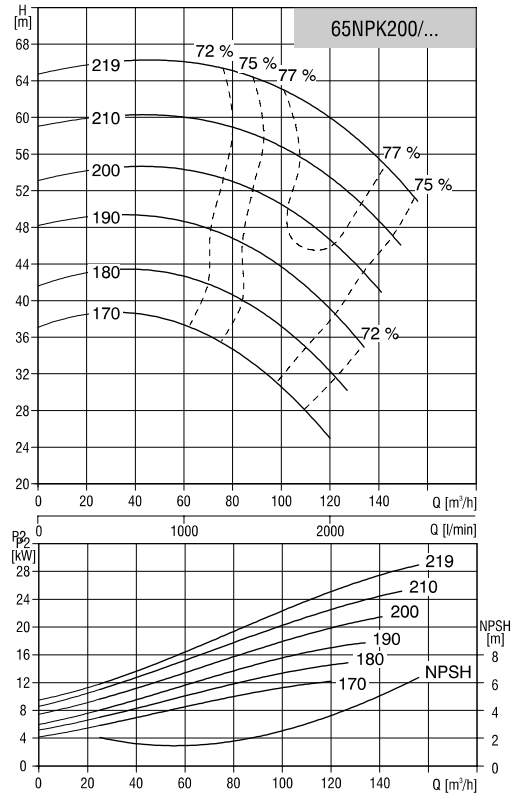
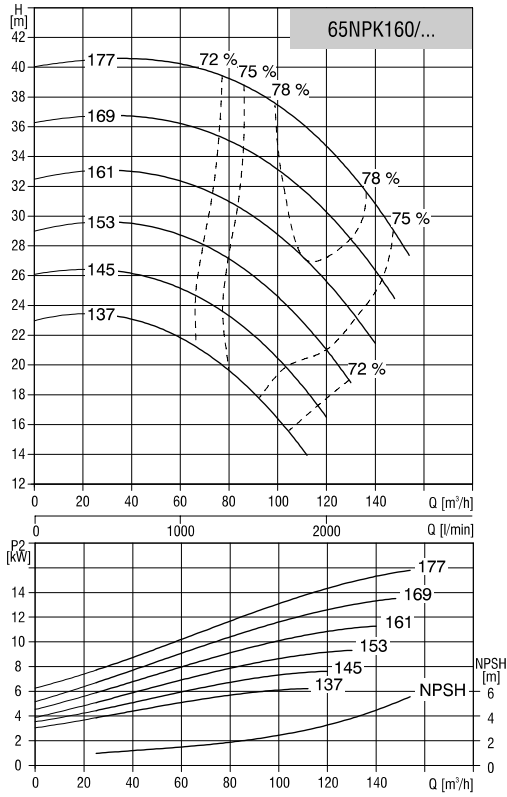

$n=2900 \text{ min}^{-1}$

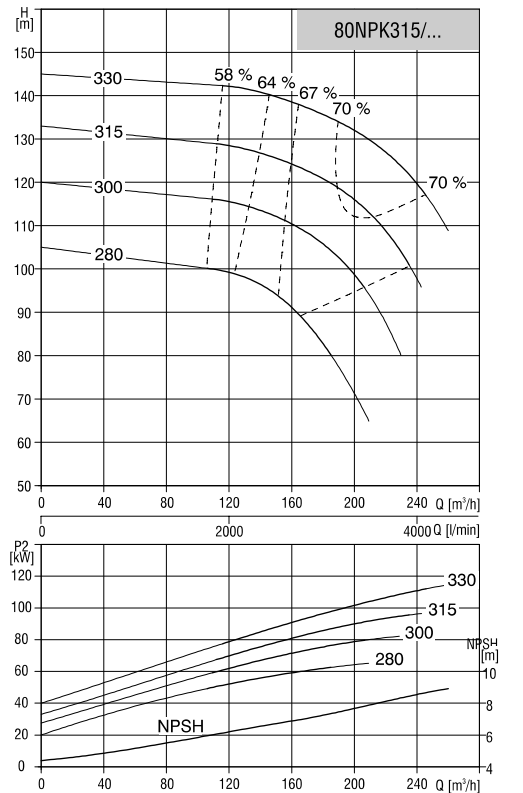
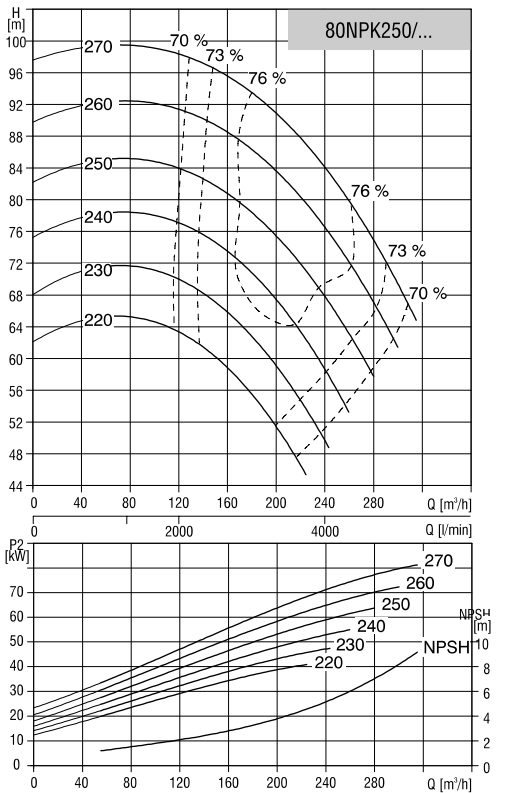
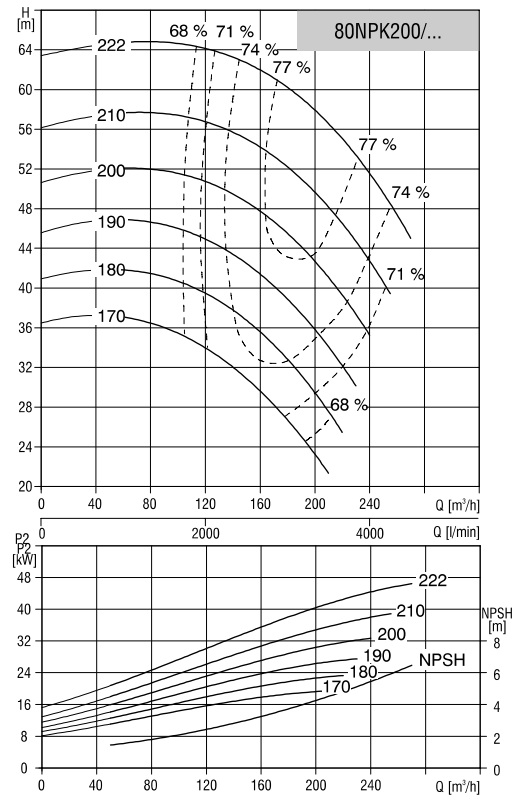
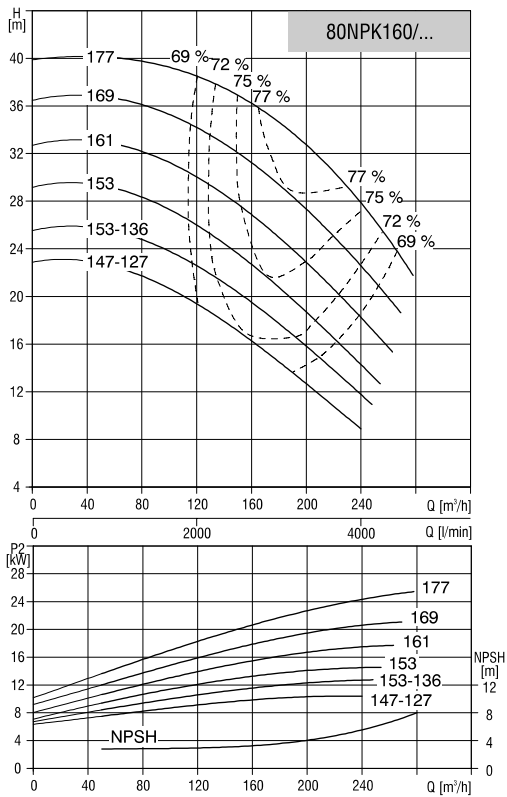

$n=2900 \text{ min}^{-1}$

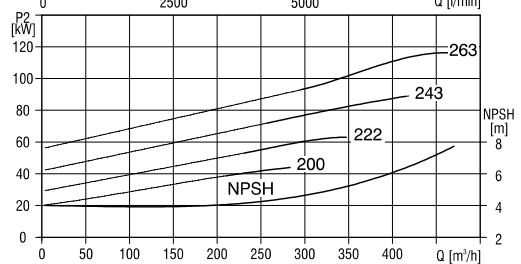
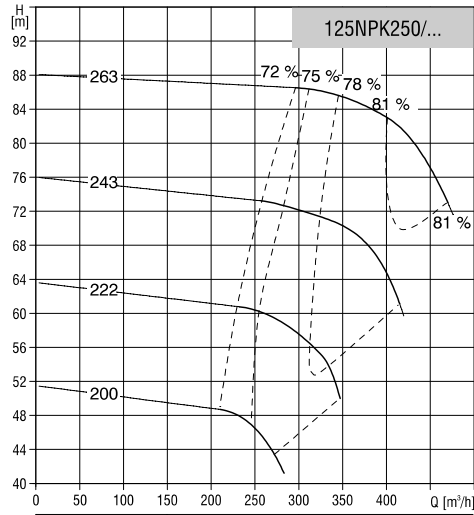
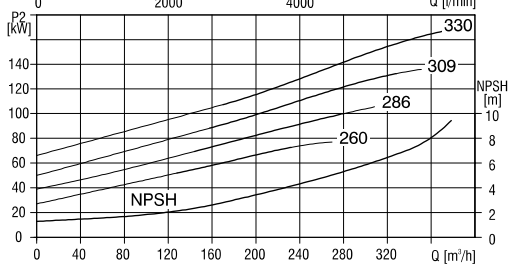
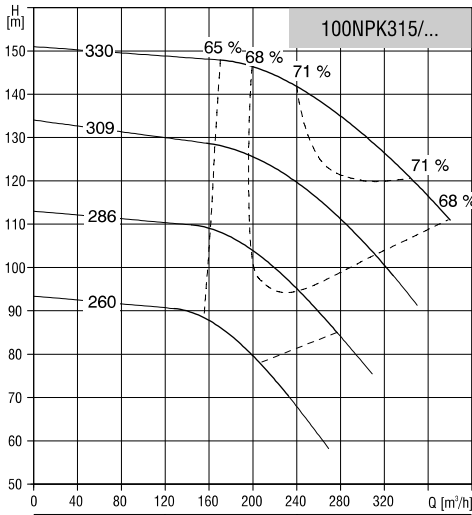
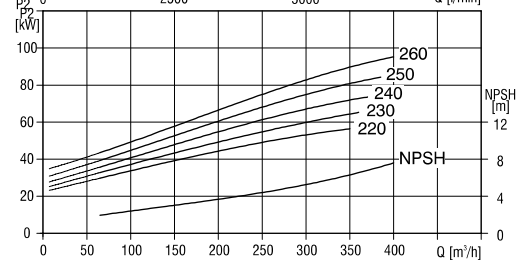
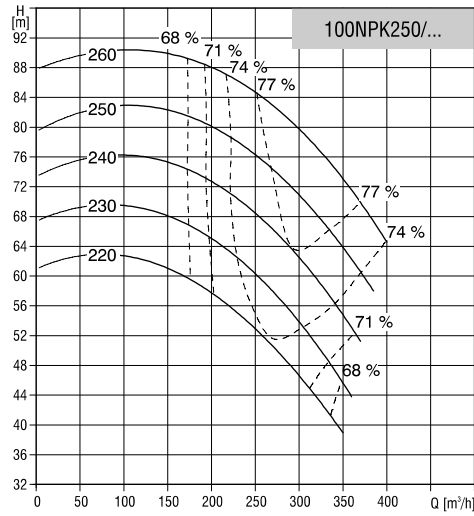
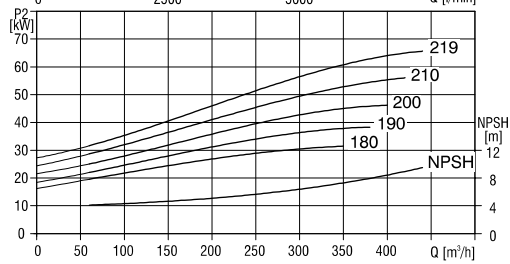
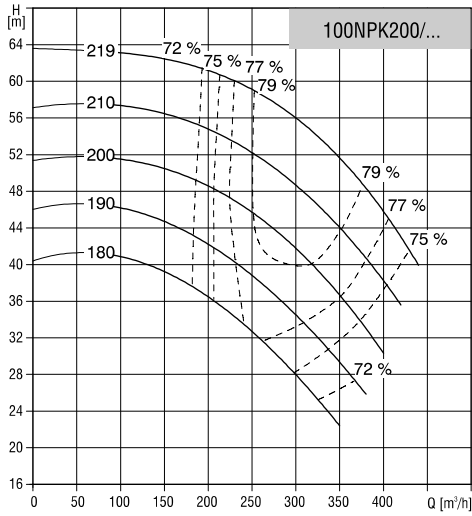

$n=2900 \text{ min}^{-1}$

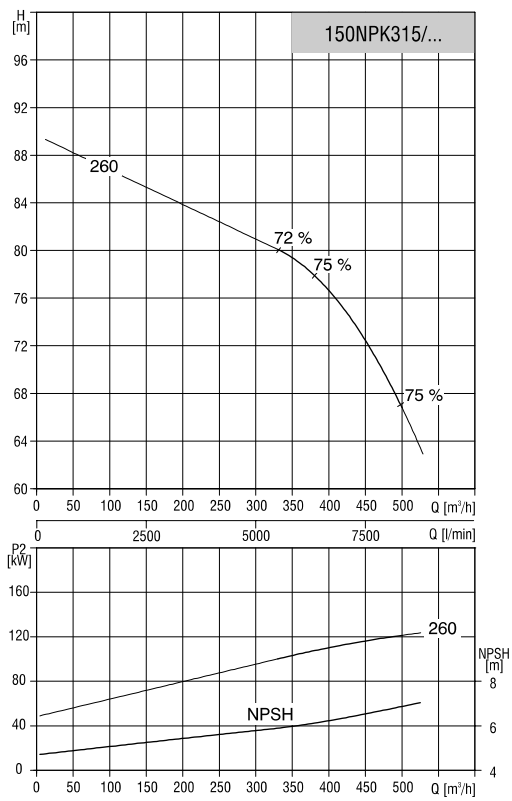

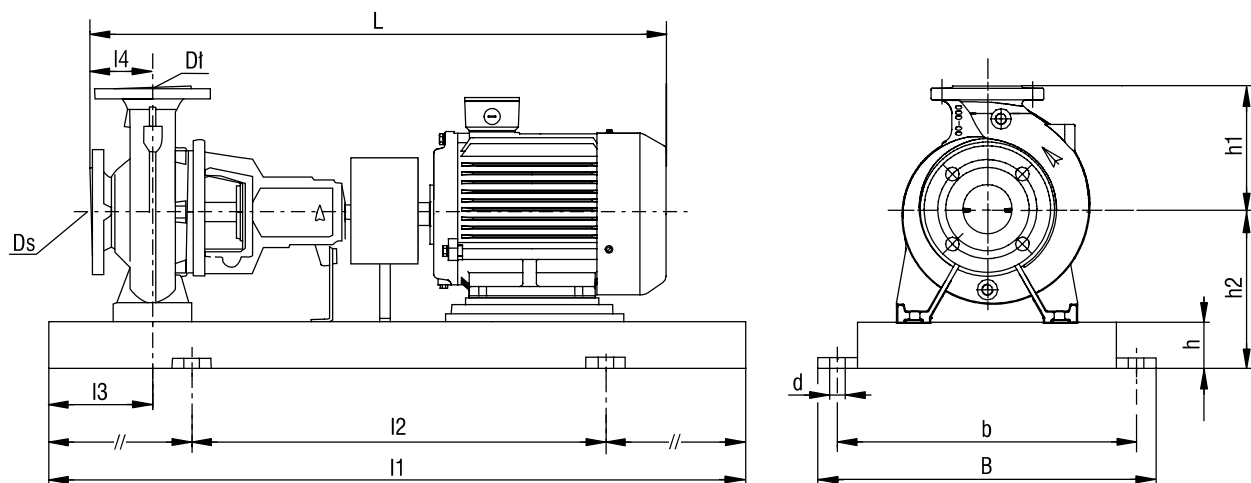

Typ pompy	Moc siln. [kW]	Wymiary [mm]													Masa [kg]
		L	l1	l2	l3	l4	B	b	h1	h2	h	d	Ds	Df	
n=1450 min <sup>-1</sup>															
32NPK125/...	0.37	767	800	540	60	80	360	320	140	177	65	19	50	32	71
32NPK125/...	0.55	817	800	540	60	80	360	320	140	177	65	19	50	32	73
32NPK125/...	0.75	817	800	540	60	80	360	320	140	177	65	19	50	32	74
32NPK125/...	1.1	877	800	540	60	80	360	320	140	177	65	19	50	32	79
32NPK160/...	0.37	767	800	540	60	80	360	320	160	197	65	19	50	32	74
32NPK160/...	0.55	817	800	540	60	80	360	320	160	197	65	19	50	32	76
32NPK160/...	0.75	817	800	540	60	80	360	320	160	197	65	19	50	32	77
32NPK160/...	1.1	877	800	540	60	80	360	320	160	197	65	19	50	32	82
32NPK160/...	1.5	877	900	600	60	80	360	350	160	197	65	19	50	32	89
32NPK200/...	0.37	767	800	540	60	80	360	320	180	225	65	19	50	32	84
32NPK200/...	0.55	817	800	540	60	80	360	320	180	225	65	19	50	32	86
32NPK200/...	0.75	817	800	540	60	80	360	320	180	225	65	19	50	32	87
32NPK200/...	1.1	877	800	540	60	80	360	320	180	225	65	19	50	32	92
32NPK200/...	1.5	877	900	600	60	80	390	350	180	225	65	19	50	32	99
32NPK200/...	2.2	941	900	600	60	80	390	350	180	225	65	19	50	32	104
32NPK200/...	3.0	978	900	600	60	80	390	350	180	225	65	19	50	32	110
40NPK125/...	0.37	767	800	540	60	80	360	320	140	177	65	19	65	40	71
40NPK125/...	0.55	817	800	540	60	80	360	320	140	177	65	19	65	40	73
40NPK125/...	0.75	817	800	540	60	80	360	320	140	177	65	19	65	40	74
40NPK125/...	1.1	877	800	540	60	80	360	320	140	177	65	19	65	40	79
40NPK125/...	1.5	877	900	600	60	80	390	350	160	197	65	19	65	40	86
40NPK160/...	0.37	767	800	540	60	80	360	320	160	197	65	19	65	40	76
40NPK160/...	0.55	817	800	540	60	80	360	320	160	197	65	19	65	40	78
40NPK160/...	0.75	817	800	540	60	80	360	320	160	197	65	19	65	40	79
40NPK160/...	1.1	877	800	540	60	80	360	320	160	197	65	19	65	40	84
40NPK160/...	1.5	877	900	600	60	80	390	350	160	197	65	19	65	40	91
40NPK160/...	2.2	941	900	600	60	80	390	350	160	197	65	19	65	40	96
40NPK160/...	3.0	978	900	600	60	80	390	350	160	197	65	19	65	40	102
40NPK200/...	0.55	837	900	600	60	100	390	350	180	225	65	19	65	40	93
40NPK200/...	0.75	837	900	600	60	100	390	350	180	225	65	19	65	40	94
40NPK200/...	1.1	897	900	600	60	100	390	350	180	225	65	19	65	40	99
40NPK200/...	1.5	897	900	600	60	100	390	350	180	225	65	19	65	40	101
40NPK200/...	2.2	961	900	600	60	100	390	350	180	225	65	19	65	40	106
40NPK200/...	3.0	998	900	600	60	100	390	350	180	225	65	19	65	40	112
40NPK200/...	4.0	998	900	600	75	100	390	350	180	225	65	19	65	40	130
40NPK250/...	1.5	897	1000	660	75	100	450	400	225	260	80	24	65	40	126
40NPK250/...	2.2	961	1000	660	75	100	450	400	225	260	80	24	65	40	131
40NPK250/...	3.0	998	1000	660	75	100	450	400	225	260	80	24	65	40	137
40NPK250/...	4.0	998	1000	660	75	100	450	400	225	260	80	24	65	40	142
40NPK250/...	5.5	1037	1000	660	75	100	450	450	225	260	80	24	65	40	157
40NPK250/...	7.5	1077	1000	660	75	100	450	450	225	260	80	24	65	40	194

Typ pompy	Moc siln. [kW]	Wymiary [mm]													Masa [kg]
		L	I1	I2	I3	I4	B	b	h1	h2	h	d	Ds	Df	
50NPK125/...	0.37	787	800	540	60	100	360	320	160	197	65	19	65	50	71
50NPK125/...	0.55	837	800	540	60	100	360	320	160	197	65	19	65	50	73
50NPK125/...	0.75	837	800	540	60	100	360	320	160	197	65	19	65	50	74
50NPK125/...	1.1	897	800	540	60	100	360	320	160	197	65	19	65	50	79
50NPK125/...	1.5	897	900	600	60	100	390	350	160	197	65	19	65	50	86
50NPK125/...	2.2	961	900	600	60	100	390	350	160	197	65	19	65	50	91
50NPK160/...	0.55	837	900	600	60	100	390	350	180	225	65	19	65	50	86
50NPK160/...	0.75	837	900	600	60	100	390	350	180	225	65	19	65	50	87
50NPK160/...	1.1	897	900	600	60	100	390	350	180	225	65	19	65	50	92
50NPK160/...	1.5	897	900	600	60	100	390	350	180	225	65	19	65	50	94
50NPK160/...	2.2	961	900	600	60	100	390	350	180	225	65	19	65	50	99
50NPK160/...	3.0	998	900	600	60	100	390	350	180	225	65	19	65	50	105
50NPK160/...	4.0	998	900	600	60	100	390	350	180	225	65	19	65	50	110
50NPK200/...	0.75	837	900	600	60	100	390	350	200	225	65	19	65	50	101
50NPK200/...	1.1	897	900	600	60	100	390	350	200	225	65	19	65	50	106
50NPK200/...	1.5	897	900	600	60	100	390	350	200	225	65	19	65	50	108
50NPK200/...	2.2	961	900	600	60	100	390	350	200	225	65	19	65	50	113
50NPK200/...	3.0	998	900	600	60	100	390	350	200	225	65	19	65	50	119
50NPK200/...	4.0	998	900	600	60	100	390	350	200	225	65	19	65	50	124
50NPK200/...	5.5	1037	900	600	60	100	390	350	200	225	65	19	65	50	139
50NPK200/...	7.5	1077	900	600	60	100	390	350	200	225	65	19	65	50	178
50NPK250/...	2.2	961	1000	660	75	100	450	400	225	260	80	24	65	50	134
50NPK250/...	3.0	998	1000	660	75	100	450	400	225	260	80	24	65	50	140
50NPK250/...	4.0	998	1000	660	75	100	450	400	225	260	80	24	65	50	145
50NPK250/...	5.5	1037	1120	740	75	100	490	440	225	260	80	24	65	50	160
50NPK250/...	7.5	1077	1120	740	75	100	490	440	225	260	80	24	65	50	199
50NPK250/...	11.0	1116	1120	740	75	100	490	440	225	260	80	24	65	50	259
65NPK125/...	0.37	787	900	600	60	100	390	350	180	225	65	19	80	65	83
65NPK125/...	0.55	837	900	600	60	100	390	350	180	225	65	19	80	65	85
65NPK125/...	0.75	837	900	600	60	100	390	350	180	225	65	19	80	65	86
65NPK125/...	1.1	897	900	600	60	100	390	350	180	225	65	19	80	65	91
65NPK125/...	1.5	897	900	600	60	100	390	350	180	225	65	19	80	65	93
65NPK125/...	2.2	961	900	600	60	100	390	350	180	225	65	19	80	65	98
65NPK125/...	3.0	998	900	600	60	100	390	350	180	225	65	19	80	65	104
65NPK160/...	0.75	837	900	600	60	100	390	350	200	225	65	19	80	65	91
65NPK160/...	1.1	897	900	600	60	100	390	350	200	225	65	19	80	65	96
65NPK160/...	1.5	897	900	600	60	100	390	350	200	225	65	19	80	65	98
65NPK160/...	2.2	961	900	600	60	100	390	350	200	225	65	19	80	65	103
65NPK160/...	3.0	998	900	600	60	100	390	350	200	225	65	19	80	65	109
65NPK160/...	4.0	998	900	600	60	100	390	350	200	225	65	19	80	65	114
65NPK160/...	5.5	1037	900	600	60	100	390	350	200	225	65	19	80	65	121
65NPK200/...	1.1	937	1000	660	75	100	450	400	225	260	80	24	80	65	115
65NPK200/...	1.5	937	1000	660	75	100	450	400	225	260	80	24	80	65	117
65NPK200/...	2.2	1001	1120	740	75	100	490	440	225	260	80	24	80	65	130
65NPK200/...	3.0	1038	1120	740	75	100	490	440	225	260	80	24	80	65	136
65NPK200/...	4.0	1038	1120	740	75	100	490	440	225	260	80	24	80	65	141
65NPK200/...	5.5	1077	1120	740	75	100	490	440	225	260	80	24	80	65	148
65NPK200/...	7.5	1116	1120	740	75	100	490	440	225	260	80	24	80	65	187
65NPK200/...	11.0	1221	1120	740	75	100	490	440	225	260	80	24	80	65	247
65NPK250/...	3.0	1148	1120	740	90	100	490	440	250	280	80	24	80	65	171
65NPK250/...	4.0	1148	1120	740	90	100	490	440	250	280	80	24	80	65	176
65NPK250/...	5.5	1187	1120	740	90	100	490	440	250	280	80	24	80	65	183
65NPK250/...	7.5	1226	1120	740	90	100	490	440	250	280	80	24	80	65	225
65NPK250/...	11.0	1331	1250	840	90	100	540	490	250	280	80	24	80	65	286
65NPK250/...	15.0	1331	1250	840	90	100	540	490	250	280	80	24	80	65	321
65NPK315/...	5.5	1212	1250	840	90	125	540	490	280	305	80	24	80	65	283
65NPK315/...	7.5	1251	1250	840	90	125	540	490	280	305	80	24	80	65	326
65NPK315/...	11.0	1356	1250	840	90	125	540	490	280	305	80	24	80	65	374
65NPK315/...	15.0	1356	1400	940	90	125	610	550	280	325	100	28	80	65	409
65NPK315/...	18.5	1441	1400	940	90	125	610	550	280	325	100	28	80	65	446
65NPK315/...	22.0	1481	1400	940	90	125	610	550	280	325	100	28	80	65	473
65NPK315/...	30.0	1511	1400	940	90	125	610	550	280	325	100	28	80	65	533

Typ pompy	Moc siln. [kW]	Wymiary [mm]													Masa [kg]
		L	I1	I2	I3	I4	B	b	h1	h2	h	d	Ds	Df	
80NPK160/...	1,1	962	1000	660	75	125	450	400	225	260	80	24	100	80	115
80NPK160/...	1,5	962	1000	660	75	125	450	400	225	260	80	24	100	80	117
80NPK160/...	2,2	1026	1000	660	75	125	450	400	225	260	80	24	100	80	122
80NPK160/...	3,0	1063	1000	660	75	125	450	400	225	260	80	24	100	80	128
80NPK160/...	4,0	1063	1120	740	75	125	490	440	225	260	80	24	100	80	133
80NPK160/...	5,5	1102	1120	740	75	125	490	440	225	260	80	24	100	80	148
80NPK160/...	7,5	1141	1120	740	75	125	490	440	225	260	80	24	100	80	191
80NPK200/...	1,5	1072	1120	740	75	125	490	440	250	262	80	24	100	80	144
80NPK200/...	2,2	1136	1120	740	75	125	490	440	250	262	80	24	100	80	149
80NPK200/...	3,0	1173	1120	740	75	125	490	440	250	262	80	24	100	80	155
80NPK200/...	4,0	1173	1120	740	75	125	490	440	250	262	80	24	100	80	160
80NPK200/...	5,5	1212	1120	740	75	125	490	440	250	262	80	24	100	80	167
80NPK200/...	7,5	1251	1120	740	75	125	490	440	250	262	80	24	100	80	210
80NPK200/...	11,0	1356	1250	840	75	125	540	490	250	262	80	24	100	80	270
80NPK200/...	15,0	1356	1250	840	75	125	540	490	250	262	80	24	100	80	286
80NPK250/...	4,0	1173	1250	840	90	125	540	490	280	280	80	24	100	80	192
80NPK250/...	5,5	1212	1250	840	90	125	540	490	280	280	80	24	100	80	199
80NPK250/...	7,5	1251	1250	840	90	125	540	490	280	280	80	24	100	80	242
80NPK250/...	11,0	1356	1250	840	90	125	540	490	280	280	80	24	100	80	290
80NPK250/...	15,0	1356	1250	840	90	125	540	490	280	280	80	24	100	80	306
80NPK250/...	18,5	1173	1250	840	90	125	540	490	280	280	80	24	100	80	343
80NPK250/...	22,0	1212	1250	840	90	125	540	490	280	280	80	24	100	80	370
80NPK315/...	7,5	1251	1250	840	90	125	540	490	315	330	80	24	100	80	271
80NPK315/...	11,0	1356	1250	840	90	125	540	490	315	330	80	24	100	80	319
80NPK315/...	15,0	1356	1400	940	90	125	610	550	315	350	100	28	100	80	354
80NPK315/...	18,5	1441	1400	940	90	125	610	550	315	350	100	28	100	80	391
80NPK315/...	22,0	1481	1400	940	90	125	610	550	315	350	100	28	100	80	418
80NPK315/...	30,0	1511	1400	940	90	125	610	550	315	350	100	28	100	80	478
80NPK315/...	37,0	1586	1400	940	90	125	610	550	315	350	100	28	100	80	532
80NPK315/...	45,0	1601	1400	940	90	125	610	550	315	350	100	28	100	80	585
100NPK200/...	3,0	1173	1120	740	90	125	490	440	280	280	80	24	125	100	170
100NPK200/...	4,0	1173	1120	740	90	125	490	440	280	280	80	24	125	100	170
100NPK200/...	5,5	1212	1120	740	90	125	490	440	280	280	80	24	125	100	177
100NPK200/...	7,5	1251	1120	740	90	125	490	440	280	280	80	24	125	100	220
100NPK200/...	11,0	1356	1250	840	90	125	540	490	280	280	80	24	125	100	280
100NPK200/...	15,0	1356	1250	840	90	125	540	490	280	280	80	24	125	100	296
100NPK200/...	18,5	1441	1250	840	90	125	540	490	280	280	80	24	125	100	332
100NPK250/...	11,0	1227	1250	840	90	140	540	490	280	305	80	24	125	100	207
100NPK250/...	15,0	1266	1250	840	90	140	540	490	280	305	80	24	125	100	250
100NPK250/...	18,5	1371	1250	840	90	140	540	490	280	30	80	24	125	100	298
100NPK250/...	22,0	1371	1400	940	90	140	610	550	280	325	100	28	125	100	333
100NPK250/...	30,0	1456	1400	940	90	140	610	550	280	325	100	28	125	100	370
100NPK250/...	37,0	1571	1400	940	90	140	610	550	280	325	100	28	125	100	430
100NPK315/...	11,0	1371	1250	840	90	140	540	490	315	330	80	24	125	100	327
100NPK315/...	15,0	1371	1400	940	90	140	610	550	315	350	100	28	125	100	362
100NPK315/...	18,5	1456	1400	940	90	140	610	550	315	350	100	28	125	100	399
100NPK315/...	22,0	1496	1400	940	90	140	610	550	315	350	100	28	125	100	426
100NPK315/...	30,0	1526	1400	940	90	140	610	550	315	350	100	28	125	100	486
100NPK315/...	37,0	1571	1400	940	90	140	610	550	315	350	100	28	125	100	549
100NPK315/...	45,0	1601	1600	940	90	140	610	550	315	350	100	28	125	100	604
100NPK315/...	55,0	1712	1600	940	90	140	610	550	315	350	100	28	125	100	652
125NPK250/...	7,5	1266	1250	540	90	140	540	490	355	330	80	24	150	125	267
125NPK250/...	11,0	1371	1400	940	90	140	610	550	355	350	100	28	150	125	334
125NPK250/...	15,0	1371	1400	940	90	140	610	550	355	350	100	28	150	125	350
125NPK250/...	18,5	1456	1400	940	90	140	610	550	355	350	100	28	150	125	387
125NPK250/...	22,0	1496	1400	940	90	140	610	550	355	350	100	28	150	125	414
125NPK250/...	30,0	1526	1400	940	90	140	610	550	355	350	100	28	150	125	474
125NPK250/...	37,0	1571	1600	940	90	140	610	550	355	350	100	28	150	125	532
125NPK250/...	45,0	1601	1600	940	90	140	610	550	355	350	100	28	150	125	599
125NPK250/...	55,0	1712	1600	940	90	140	610	550	355	350	100	28	150	125	648
125NPK315/...	11,0	1431	1600	1060	110	140	660	600	355	380	100	28	150	125	402

Typ pompy	Moc siln. [kW]	Wymiary [mm]													Masa [kg]
		L	I1	I2	I3	I4	B	b	h1	h2	h	d	Ds	Df	
125NPK315/...	15.0	1431	1600	1060	110	140	660	600	355	380	100	28	150	125	420
125NPK315/...	18.5	1516	1600	1060	110	140	660	600	355	380	100	28	150	125	418
125NPK315/...	22.0	1556	1600	1060	110	140	660	600	355	380	100	28	150	125	455
125NPK315/...	30.0	1586	1600	1060	110	140	660	600	355	380	100	28	150	125	542
125NPK315/...	37.0	1631	1800	1200	110	140	730	670	355	380	100	28	150	125	577
125NPK315/...	45.0	1661	1800	1200	110	140	730	670	355	380	100	28	150	125	622
125NPK315/...	55.0	1772	1800	1200	110	140	730	670	355	380	100	28	150	125	681
150NPK200/...	5.5	1247	1800	1200	110	160	730	670	400	380	100	28	200	150	375
150NPK200/...	7.5	1286	1800	1200	110	160	730	670	400	380	100	28	200	150	418
150NPK200/...	11.0	1391	1800	1200	110	160	730	670	400	380	100	28	200	150	466
150NPK200/...	15.0	1391	1800	1200	110	160	730	670	400	380	100	28	200	150	482
150NPK200/...	18.0	1476	1800	1200	110	160	730	670	400	380	100	28	200	150	519
150NPK200/...	22.0	1516	1800	1200	110	160	730	670	400	380	100	28	200	150	544
150NPK200/...	30.0	1546	1800	1200	110	160	730	670	400	380	100	28	200	150	604
150NPK315/...	11.0	1451	1800	1200	110	160	730	670	400	380	100	28	200	150	465
150NPK315/...	15.0	1451	1800	1200	110	160	730	670	400	380	100	28	200	150	481
150NPK315/...	18.5	1536	1800	1200	110	160	730	670	400	380	100	28	200	150	518
150NPK315/...	22.0	1576	1800	1200	110	160	730	670	400	380	100	28	200	150	545
150NPK315/...	30.0	1606	1800	1200	110	160	730	670	400	380	100	28	200	150	605
150NPK315/...	37.0	1651	1800	1200	110	160	730	670	400	380	100	28	200	150	669
150NPK315/...	45.0	1681	1800	1200	110	160	730	670	400	380	100	28	200	150	694
150NPK315/...	55.0	1747	1800	1200	110	160	730	670	400	380	100	28	200	150	818
150NPK315/...	75.0	1822	1800	1200	110	160	730	670	400	380	100	28	200	150	908
n=2900 min <sup>-1</sup>															
32NPK125/...	1.1	817	800	540	60	80	360	320	140	177	65	19	50	32	74
32NPK125/...	1.5	877	800	540	60	80	360	320	140	177	65	19	50	32	80
32NPK125/...	2.2	877	900	600	60	80	390	350	140	177	65	19	50	32	88
32NPK125/...	3.0	941	900	600	60	80	390	350	140	177	65	19	50	32	92
32NPK125/...	4.0	978	900	600	60	80	390	350	140	177	65	19	50	32	101
32NPK125/...	5.5	1017	1000	660	60	80	390	350	140	177	65	19	50	32	119
32NPK125/...	7.5	1017	1000	660	60	80	390	350	140	177	65	19	50	32	122
32NPK160/...	2.2	877	900	600	60	80	390	350	160	197	65	19	50	32	91
32NPK160/...	3.0	941	900	600	60	80	390	350	160	197	65	19	50	32	95
32NPK160/...	4.0	978	900	600	60	80	390	350	160	197	65	19	50	32	104
32NPK160/...	5.5	1017	1000	660	60	80	450	400	160	212	80	24	50	32	122
32NPK160/...	7.5	1017	1000	660	60	80	450	400	160	212	80	24	50	32	125
32NPK160/...	11.0	1161	1120	740	60	80	450	400	160	212	80	24	50	32	197
32NPK160/...	15.0	1161	1120	740	60	80	450	400	160	212	80	24	50	32	215
32NPK200/...	3.0	941	900	600	60	80	390	350	180	225	65	19	50	32	105
32NPK200/...	4.0	978	900	600	60	80	390	350	180	225	65	19	50	32	114
32NPK200/...	5.5	1017	1000	660	60	80	450	400	180	240	80	24	50	32	132
32NPK200/...	7.5	1017	1000	660	60	80	450	400	180	240	80	24	50	32	135
32NPK200/...	11.0	1161	1120	740	60	80	490	440	180	240	80	24	50	32	217
32NPK200/...	15.0	1161	1120	740	60	80	490	440	180	240	80	24	50	32	225
32NPK200/...	18.5	1256	1120	740	60	80	490	440	180	240	80	24	50	32	245
32NPK200/...	22.0	1266	1250	740	60	80	490	440	180	240	80	24	50	32	285
40NPK125/...	1.5	877	800	540	60	80	360	320	140	177	65	19	65	40	80
40NPK125/...	2.2	877	900	600	60	80	390	350	140	177	65	19	65	40	88
40NPK125/...	3.0	941	900	600	60	80	390	350	140	177	65	19	65	40	92
40NPK125/...	4.0	978	900	600	60	80	390	350	140	177	65	19	65	40	101
40NPK125/...	5.5	1017	1000	660	60	80	450	400	140	212	80	24	65	40	119
40NPK125/...	7.5	1017	1000	660	60	80	450	400	140	212	80	24	65	40	122
40NPK125/...	11.0	1161	1120	740	60	80	450	400	140	212	80	24	65	40	231
40NPK160/...	3.0	941	900	600	60	80	390	350	160	197	65	19	65	40	97
40NPK160/...	4.0	978	900	600	60	80	390	350	160	197	65	19	65	40	106
40NPK160/...	5.5	1017	1000	660	60	80	450	400	160	212	80	24	65	40	124
40NPK160/...	7.5	1017	1000	660	60	80	450	400	160	212	80	24	65	40	127
40NPK160/...	11.0	1161	1120	740	60	80	490	440	160	240	80	24	65	40	209
40NPK160/...	15.0	1161	1120	740	60	80	490	440	160	240	80	24	65	40	217
40NPK160/...	18.5	1256	1120	740	60	80	490	440	180	240	80	24	65	40	238
40NPK200/...	4.0	998	900	600	60	100	390	350	180	225	65	19	65	40	116
40NPK200/...	5.5	1037	1000	660	60	100	450	400	180	240	80	24	65	40	134
40NPK200/...	7.5	1037	1000	660	60	100	450	400	180	240	80	24	65	40	137
40NPK200/...	11.0	1181	1120	740	60	100	490	440	180	240	80	24	65	40	219
40NPK200/...	15.0	1236	1120	740	60	100	490	440	180	240	80	24	65	40	227
40NPK200/...	18.5	1266	1120	740	60	100	490	440	180	240	80	24	65	40	250
40NPK200/...	22.0	1266	1250	740	60	100	490	440	180	240	80	24	65	40	345
40NPK200/...	30.0	1336	1250	740	60	100	490	440	180	240	80	24	65	40	429

Typ pompy	Moc siln. [kW]	Wymiary [mm]													Masa [kg]
		L	I1	I2	I3	I4	B	b	h1	h2	h	d	Ds	Df	
40NPK250/...	11,0	1181	1250	840	75	100	540	490	225	260	80	24	65	40	246
40NPK250/...	15,0	1181	1250	840	75	100	540	490	225	260	80	24	65	40	254
40NPK250/...	18,5	1236	1250	840	75	100	540	490	225	260	80	24	65	40	277
40NPK250/...	22,0	1266	1250	840	75	100	540	490	225	260	80	24	65	40	315
40NPK250/...	30,0	1336	1400	940	75	100	610	550	225	300	100	28	65	40	402
40NPK250/...	37,0	1366	1400	940	75	100	610	550	225	300	100	28	65	40	424
50NPK125/...	3,0	961	900	600	60	100	390	350	160	197	65	19	65	50	92
50NPK125/...	4,0	998	900	600	60	100	390	350	160	197	65	19	65	50	101
50NPK125/...	5,5	1037	1000	660	60	100	450	400	160	212	80	24	65	50	119
50NPK125/...	7,5	1037	1000	660	60	100	450	400	160	212	80	24	65	50	122
50NPK125/...	11,0	1181	1120	740	60	100	490	440	160	240	80	24	65	50	204
50NPK125/...	15,0	1181	1120	740	60	100	490	440	160	240	80	24	65	50	212
50NPK160/...	4,0	998	900	600	60	100	390	350	180	225	65	19	65	50	109
50NPK160/...	5,5	1037	1000	660	60	100	450	400	180	240	80	24	65	50	127
50NPK160/...	7,5	1037	1000	660	60	100	450	400	180	240	80	24	65	50	130
50NPK160/...	11,0	1181	1120	740	60	100	490	440	180	240	80	24	65	50	212
50NPK160/...	15,0	1181	1120	740	60	100	490	440	180	240	80	24	65	50	220
50NPK160/...	18,5	1236	1120	740	60	100	490	440	180	240	80	24	65	50	243
50NPK160/...	22,0	1266	1120	740	60	100	490	440	180	240	80	24	65	50	312
50NPK200/...	7,5	1037	1000	660	60	100	450	400	200	240	80	24	65	50	144
50NPK200/...	11,0	1181	1120	740	60	100	490	440	200	240	80	24	65	50	226
50NPK200/...	15,0	1181	1120	740	60	100	490	440	200	240	80	24	65	50	234
50NPK200/...	18,5	1236	1120	740	60	100	490	440	200	240	80	24	65	50	257
50NPK200/...	22,0	1266	1120	740	60	100	490	440	200	260	80	24	65	50	295
50NPK200/...	30,0	1366	1250	840	60	100	540	490	200	280	80	24	65	50	375
50NPK200/...	37,0	1366	1250	840	60	100	540	490	200	280	80	24	65	50	397
50NPK200/...	45,0	1396	1250	840	60	100	540	490	200	280	80	24	65	50	461
50NPK250/...	15,0	1181	1250	840	75	100	540	490	225	260	80	24	65	50	357
50NPK250/...	18,5	1236	1250	840	75	100	540	490	225	260	80	24	65	50	280
50NPK250/...	22,0	1266	1250	840	75	100	540	490	225	260	80	24	65	50	318
50NPK250/...	30,0	1336	1400	840	75	100	610	550	225	300	100	28	65	50	405
50NPK250/...	37,0	1336	1400	840	75	100	610	550	225	300	100	28	65	50	427
50NPK250/...	45,0	1386	1400	940	75	100	610	550	225	325	100	28	65	50	503
50NPK250/...	55,0	1406	1600	940	75	100	610	550	225	325	100	28	65	50	615
65NPK125/...	4,0	998	900	600	60	100	390	350	180	225	65	19	80	65	108
65NPK125/...	5,5	1037	1000	660	60	100	450	400	180	240	80	24	80	65	126
65NPK125/...	7,5	1037	1000	660	60	100	450	400	180	240	80	24	80	65	129
65NPK125/...	11,0	1181	1120	740	60	100	490	440	180	240	80	24	80	65	211
65NPK125/...	15,0	1181	1120	740	60	100	490	440	180	240	80	24	80	65	219
65NPK125/...	18,5	1236	1120	740	60	100	490	440	180	240	80	24	80	65	242
65NPK125/...	22,0	1266	1120	740	60	100	4690	440	180	240	80	24	80	65	275
65NPK160/...	5,5	1037	1000	660	60	100	450	400	200	240	80	24	80	65	131
65NPK160/...	7,5	1037	1000	660	60	100	450	400	200	240	80	24	80	65	134
65NPK160/...	11,0	1181	1120	740	60	100	490	440	200	240	80	24	80	65	216
65NPK160/...	15,0	1181	1120	740	60	100	490	440	200	240	80	24	80	65	224
65NPK160/...	18,5	1236	1120	740	60	100	490	440	200	240	80	24	80	65	247
65NPK160/...	22,0	1266	1120	740	60	100	490	440	200	260	80	24	80	65	285
65NPK160/...	30,0	1336	1250	840	60	100	490	440	200	260	80	28	80	65	341
65NPK160/...	37,0	1336	1250	840	60	100	490	440	200	260	80	28	80	65	362
65NPK200/...	11,0	1221	1250	840	75	225	540	490	225	260	80	24	80	65	237
65NPK200/...	15,0	1221	1250	840	75	225	540	490	225	260	80	24	80	65	245
65NPK200/...	18,5	1276	1250	840	75	225	540	490	225	260	80	24	80	65	268
65NPK200/...	22,0	1306	1250	840	75	225	540	490	225	260	80	24	80	65	337
65NPK200/...	30,0	1376	1400	940	75	225	610	550	225	300	100	28	80	65	393
65NPK200/...	37,0	1376	1400	940	75	225	610	550	225	300	100	28	80	65	415
65NPK200/...	45,0	1426	1400	940	75	225	610	550	225	300	100	28	80	65	495
65NPK200/...	55,0	1516	1600	1060	75	225	660	600	225	325	100	28	80	65	620
65NPK200/...	75,0	1598	1600	1060	75	225	660	600	225	325	100	28	80	65	705
65NPK250/...	22,0	1416	1250	840	90	250	540	490	250	280	80	24	80	65	342
65NPK250/...	30,0	1486	1400	940	90	250	610	550	250	300	100	28	80	65	428
65NPK250/...	37,0	1486	1400	940	90	250	610	550	250	300	100	28	80	65	450
65NPK250/...	45,0	1536	1400	940	90	250	610	550	250	325	100	28	80	65	526
65NPK250/...	55,0	1626	1600	1060	90	250	660	600	250	350	100	28	80	65	662
65NPK250/...	75,0	1702	1600	1060	90	250	660	600	250	350	100	28	80	65	749

Typ pompy	Moc siln. [kW]	Wymiary [mm]													Masa [kg]
		L	I1	I2	I3	I4	B	b	h1	h2	h	d	Ds	Df	
65NPK315/...	37.0	1511	1600	1060	90	125	660	600	280	325	100	28	80	65	494
65NPK315/...	45.0	1561	1600	1060	90	125	660	600	280	325	100	28	80	65	570
65NPK315/...	55.0	1651	1800	1200	90	125	730	670	280	350	100	28	80	65	713
65NPK315/...	75.0	1787	1800	1200	90	125	730	670	280	380	100	28	80	65	499
65NPK315/...	90.0	1837	1800	1200	90	125	730	670	280	380	100	28	80	65	864
65NPK315/...	110.0	1962	2000	1340	90	125	910	830	315	435	100	28	80	65	1225
80NPK160/...	7.5	1102	1120	740	75	125	490	440	225	260	80	24	100	80	151
80NPK160/...	11.0	1246	1250	840	75	125	540	490	225	260	80	24	100	80	237
80NPK160/...	15.0	1246	1250	840	75	125	540	490	225	260	80	24	100	80	245
80NPK160/...	18.5	1301	1250	840	75	125	540	490	225	260	80	24	100	80	268
80NPK160/...	22.0	1331	1250	840	75	125	540	490	225	260	80	24	100	80	307
80NPK160/...	30.0	1401	1400	940	75	125	610	550	225	300	100	28	100	80	393
80NPK160/...	37.0	1401	1400	940	75	125	610	550	225	300	100	28	100	80	415
80NPK200/...	18.5	1411	1250	840	75	125	540	490	250	260	100	24	100	80	287
80NPK200/...	22.0	1441	1250	840	75	125	540	490	250	260	100	24	100	80	326
80NPK200/...	30.0	1511	1400	940	75	125	610	550	250	300	100	28	100	80	412
80NPK200/...	37.0	1511	1400	940	75	125	610	550	250	300	100	28	100	80	434
80NPK200/...	45.0	1561	1400	940	75	125	610	550	250	325	100	28	100	80	510
80NPK200/...	55.0	1651	1600	1060	75	125	660	600	250	350	100	28	100	80	646
80NPK200/...	75.0	1727	1800	1200	75	125	730	670	250	380	100	28	100	80	735
80NPK200/...	90.0	1792	1800	1200	75	125	730	670	250	380	100	28	100	80	800
80NPK200/...	110.0	1977	2000	1340	75	125	910	830	250	380	100	28	100	80	1165
80NPK250/...	37.0	1511	1400	940	90	125	610	550	280	300	100	28	100	80	454
80NPK250/...	45.0	1561	1400	940	90	125	610	550	280	300	100	28	100	80	530
80NPK250/...	55.0	1651	160	1060	90	125	660	600	280	300	100	28	100	80	666
80NPK250/...	75.0	1727	1800	1200	90	125	730	670	280	300	100	28	100	80	755
80NPK250/...	90.0	1777	1800	1200	90	125	730	670	280	300	100	28	100	80	820
80NPK315/...	45.0	1561	1800	1200	90	125	730	670	315	350	100	28	100	80	599
80NPK315/...	55.0	1651	1800	1200	90	125	730	670	315	350	100	28	100	80	719
80NPK315/...	75.0	1787	1800	1200	90	125	730	670	315	380	100	28	100	80	805
80NPK315/...	90.0	1837	1800	1200	90	125	730	670	315	380	100	28	100	80	870
80NPK315/...	110.0	1962	2000	1340	90	125	910	830	315	435	120	28	100	80	1251
100NPK200/...	30.0	1511	1400	940	90	125	610	550	280	300	100	28	125	100	422
100NPK200/...	37.0	1511	1400	940	90	125	610	550	280	300	100	28	125	100	444
100NPK200/...	45.0	1561	1400	940	90	125	610	550	280	325	100	28	125	100	520
100NPK200/...	55.0	1650	1600	1060	90	125	660	600	280	350	100	28	125	100	656
100NPK200/...	75.0	1727	1800	1200	90	125	730	670	280	380	100	28	125	100	745
100NPK200/...	90.0	1777	1800	1200	90	125	730	670	280	380	100	28	125	100	810
100NPK250/...	45.0	1576	1600	1060	90	140	660	600	280	325	100	28	125	100	555
100NPK250/...	55.0	1666	1600	1060	90	140	660	600	280	350	100	28	125	100	674
100NPK250/...	75.0	1742	1800	1200	90	140	730	670	280	380	100	28	125	100	763
100NPK250/...	90.0	1792	1800	1200	90	140	730	670	280	380	100	28	125	100	828
100NPK250/...	110.0	1917	2000	1340	90	140	910	830	280	435	100	28	125	100	1209
100NPK315/...	55.0	1666	1800	1200	90	140	730	670	315	350	100	28	125	100	726
100NPK315/...	75.0	1742	1800	1200	90	140	730	670	315	380	100	28	125	100	793
100NPK315/...	90.0	1792	1800	1200	90	140	730	670	315	380	100	28	125	100	858
100NPK315/...	110.0	1977	200	1340	90	140	910	830	315	435	120	28	125	100	1260
125NPK250/...	37.0	1526	1600	1060	90	140	660	600	355	350	100	28	150	125	495
125NPK250/...	45.0	1576	1600	1060	90	140	660	600	355	350	100	28	150	125	571
125NPK250/...	55.0	1666	1800	1200	90	140	730	670	355	350	100	28	150	125	715
125NPK250/...	75.0	1742	1800	1200	90	140	730	670	355	380	100	28	150	125	781
125NPK250/...	90.0	1792	1800	1200	90	140	730	670	355	380	100	28	150	125	846
125NPK250/...	110.0	1977	2000	1340	90	140	910	830	355	435	120	28	150	125	1254
150NPK315/...	90.0	1792	1800	1200	110	160	730	670	400	380	100	28	200	150	781
150NPK315/...	110.0	1977	2000	1340	110	160	910	830	400	435	120	28	200	150	1319

## DANE SILNIKÓW

Silniki przeznaczone do napędu pomp NPK, charakteryzują się:

- formą wykonania kołnierзовą lub kołnierзовą na łapach.

Klasa izolacji silnika F (stosowana w pompach NPK) oznacza, że przy temperaturze otoczenia 40°C przyrost temperatur uzwojeń silnika może wynieść maksymalnie 105°C.

W pompach stosuje się silniki posiadające stopień ochrony IP55.

Kod IP, który posiadają silniki elektryczne oznacza stopień ochrony zapewnianej przez obudowę przed dostępem do części niebezpiecznych, wchodzeniem obcych ciał stałych i/lub wnikaniem wody.

Kod IP składa się z liter kodu IP oraz dwóch obowiązkowych cyfr oznaczających:

Pierwsza cyfra (ochrona przed dostaniem się obcych ciał stałych)		Druga cyfra (ochrona przed wnikaniem wody i szkodliwymi jej skutkami)	
IP	Opis stopnia ochrony	IP	Opis stopnia ochrony
5	ochrona przed pyłem nie zapewniająca całkowitej szczelności	5	przed strugami wody

Typ silnika	Moc znamionowa [kW]	Napięcie [V]	Sprawność znamionowa [%]	Współczynnik mocy $\cos \phi$	Prąd nominalny $I_n$ [A]	Krotność prądu rozruch. $I_r/I_n$	Klasa izolacji	Stopień ochrony
1450 min <sup>-1</sup>								
MG 71B	0,37	3x220-240 / 380-415	71	0,77 / 0,67	1,9 / 1,0	4,0 / 4,4	F	IP 55
MG 80A	0,55	3x220-240 / 380-415	77	0,79 / 0,70	2,6 / 1,5	4,3 / 4,7	F	IP 55
MG 80B	0,75	3x220-240 / 380-415	78	0,79 / 0,70	3,3 / 1,9	4,3 / 4,7	F	IP 55
MG 90SA	1,1	3x220-240 / 380-415	78	0,78 / 0,71	5,0 / 2,9	4,3 / 4,7	F	IP 55
MG 90LA	1,5	3x220-240 / 380-415	80	0,80 / 0,74	6,4 / 3,7	5,0 / 5,5	F	IP 55
MG 100LB	2,2	3x220-240 / 380-415	82	0,80 / 0,73	9,2 / 5,0	5,2 / 5,7	F	IP 55
MG 112MA	3,0	3x220-240 / 380-415	85	0,80 / 0,74	12,0 / 6,9	6,2 / 6,7	F	IP 55
MG 112MB	4,0	3x220-240 / 380-415	87	0,82 / 0,76	15,4 / 8,9	6,6 / 7,2	F	IP 55
MG 132SC	5,5	3x220-240 / 380-415	87	0,80 / 0,74	22,0 / 12,6	6,3 / 6,9	F	IP 55
MMG 132M	7,5	3x220-240 / 380-415	89	0,84	24,2 / 14,0	7,8	F	IP 55
MMG 160MA	11,0	3x220-240 / 380-415	90	0,84	36,5 / 21,0	7,4	F	IP 55
MMG 160MB	15,0	3x220-240 / 380-415	89	0,85	49,5 / 28,5	7,8	F	IP 55
MMG 180M	18,5	3x220-240 / 380-415	91	0,86	58,0 / 33,5	7,6	F	IP 55
MMG 180L	22,0	3x220-240 / 380-415	91	0,86	66,5 / 38,5	7,8	F	IP 55
MMG 200L	30,0	3x220-240 / 380-415	91	0,86	95,0 / 55,0	7,5	F	IP 55
MMG 225S	37,0	3x220-240 / 380-415	92	0,87	112,0 / 65,0	6,9	F	IP 55
MMG 225M	45,0	3x220-240 / 380-415	92	0,87	140,0 / 80,5	7,5	F	IP 55
MMG 250M	55,0	3x220-240 / 380-415	93	0,87	172,0 / 99,0	7,5	F	IP 55
MMG 280S	75,0	3x220-240 / 380-415	94	0,87	222,0 / 128,0	7,4	F	IP 55
2900 min <sup>-1</sup>								
MG 80B	1,1	3x220-240 / 380-415	81	0,81 / 0,75	4,5 / 2,65	5,8 / 6,3	F	IP 55
MG 90SA	1,5	3x220-240 / 380-415	82	0,85 / 0,79	5,9 / 3,4	6,3 / 6,9	F	IP 55
MG 90LA	2,2	3x220-240 / 380-415	84	0,87 / 0,82	8,25 / 4,75	7,0 / 7,6	F	IP 55
MG 100LB	3,0	3x220-240 / 380-415	85	0,88 / 0,82	10,8 / 6,25	7,8 / 8,5	F	IP 55
MG 112MB	4,0	3x220-240 / 380-415	86	0,90 / 0,87	13,8 / 8,0	8,7 / 9,5	F	IP 55
MG 132SB	5,5	3x220-240 / 380-415	87	0,89 / 0,86	19,0 / 11,0	8,9 / 9,7	F	IP 55
MG 132SC	7,5	3x220-240 / 380-415	88	0,87 / 0,81	26,5 / 15,2	9,1 / 9,9	F	IP 55
MMG160MA	11,0	3x220-240 / 380-415	89	0,88	34,5 / 20,0	5,6	F	IP 55
MMG 160MB	15,0	3x220-240 / 380-415	91	0,89	47,5 / 27,5	5,8	F	IP 55
MMG 160L	18,5	3x220-240 / 380-415	92	0,90	57,0 / 33,0	6,5	F	IP 55
MMG 180M	22,0	3x220-240 / 380-415	91	0,89	67,5 / 39,0	7,4	F	IP 55
MMG 200LA	30,0	3x220-240 / 380-415	91	0,89	91,5 / 53,0	7	F	IP 55
MMG 200LB	37,0	3x220-240 / 380-415	92	0,89	110 / 64	7,6	F	IP 55
MMG 225M	45,0	3x220-240 / 380-415	93	0,89	136 / 78	7,4	F	IP 55
MMG 250M	55,0	3x220-240 / 380-415	94	0,90	166 / 95,5	7,9	F	IP 55
MMG 280S	75,0	3x220-240 / 380-415	94	0,89	222 / 128	6,6	F	IP 55
MMG 280M	95,0	3x220-240 / 380-415	95	0,90	265 / 152	7,2	F	IP 55
MMG 315S	110,0	3x220-240 / 380-415	94	0,91	325 / 188	7,5	F	IP 55

Silniki stosowane w typoszeregu pomp NPK odpowiadają pierwszej lub drugiej klasie sprawności EFF1, EFF2.

## Schematy przyłączy elektrycznych silników standardowych

Schematy połączeń dla pomp z 6 zaciskami w skrzyni.

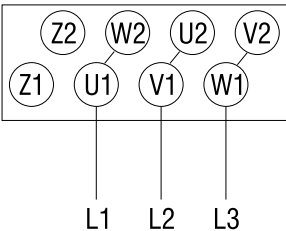
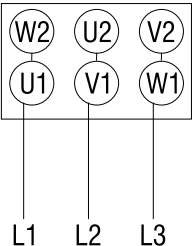
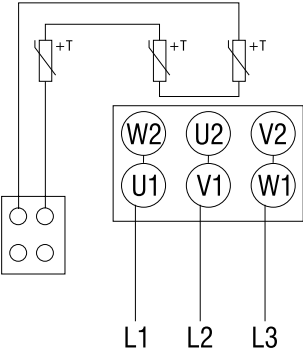
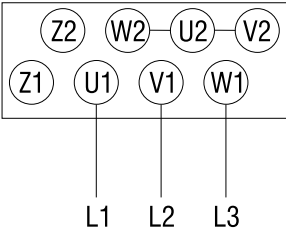
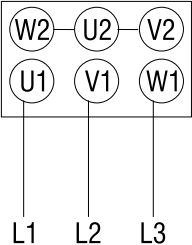
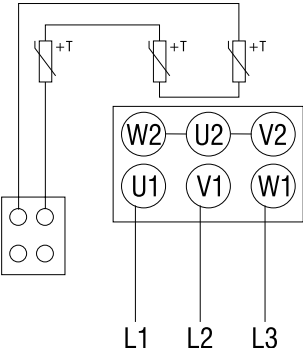
<p>Dla pomp o mocy  <math>P=0,25 \div 0,75 \text{ kW}</math>  <math>n=1450 \text{ min}^{-1}</math></p>	<p>Dla pomp o mocy  <math>P=1,1 \div 2,2 \text{ kW}</math> <math>n=1450 \text{ min}^{-1}</math>  <math>P=1,1 \div 2,2 \text{ kW}</math> <math>n=2900 \text{ min}^{-1}</math></p>	<p>Dla pomp o mocy  <math>P=3,0 \div 75,0 \text{ kW}</math> <math>n=1450 \text{ min}^{-1}</math>  <math>P=3,0 \div 110,0 \text{ kW}</math> <math>n=2900 \text{ min}^{-1}</math></p>
<p>Połączenie <math>\Delta</math></p>	<p>Połączenie <math>\Delta</math></p>	<p>Połączenie <math>\Delta</math></p>
		<p>wraz z wyprowadzeniem zabezpieczenia termicznego</p> 
<p>Połączenie <math>\lambda</math></p>	<p>Połączenie <math>\lambda</math></p>	<p>Połączenie <math>\lambda</math></p>
		<p>wraz z wyprowadzeniem zabezpieczenia termicznego</p> 

Przed podłączeniem należy zawsze sprawdzić dane na tabliczce znamionowej silnika.